

RESPONSE™ 5.5/6.0mm System

SURGICAL TECHNIQUE

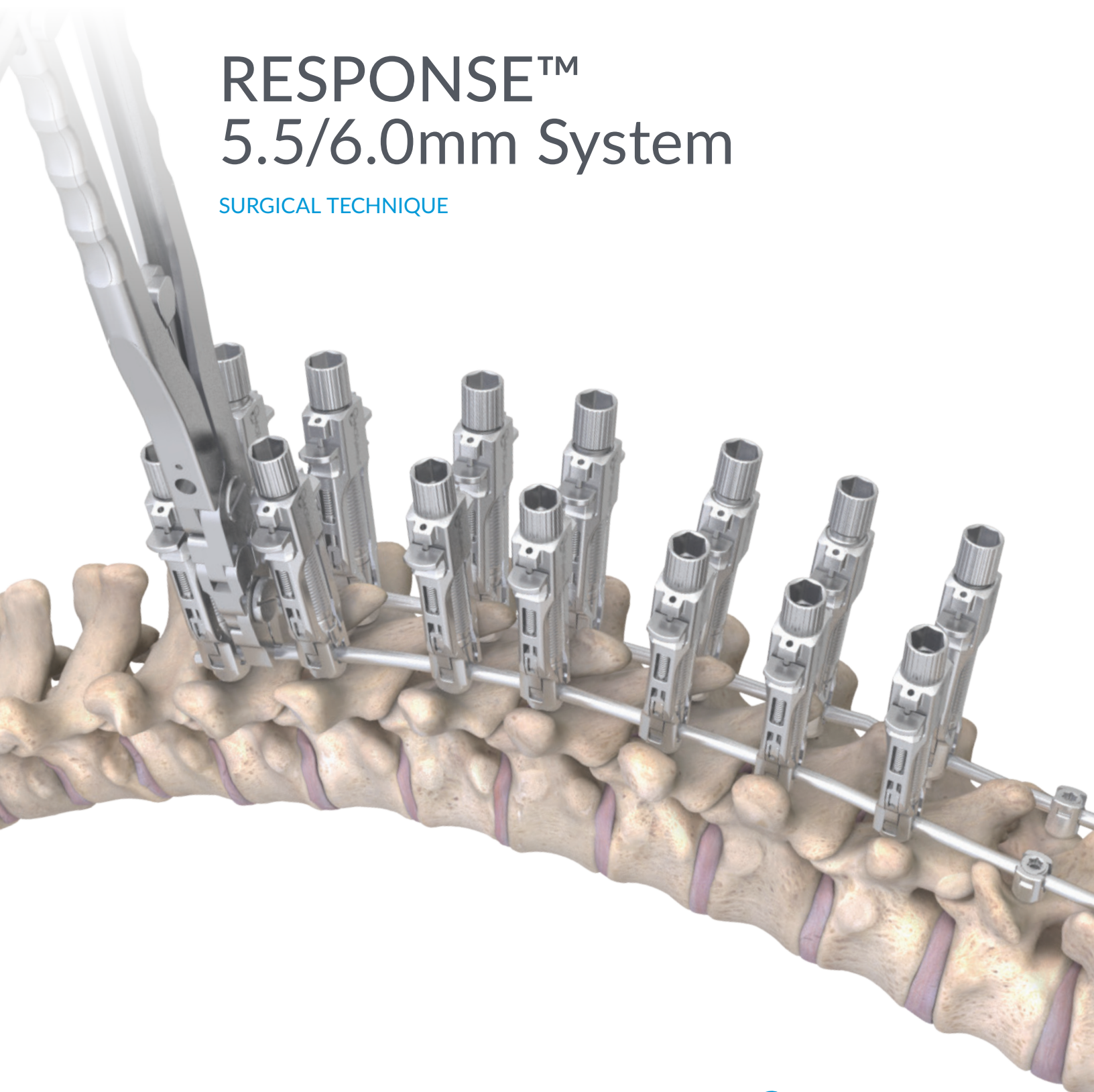



TABLE OF CONTENTS

System Overview

Indications.....	4
System Features	4
Implant Classification	5
Implants.....	6
Instruments.....	11

Pedicle Screw Surgical Technique

Perform Thoracic Facetectomy	21
Prepare Pedicles.....	22
Pedicle Screw Driver Application.....	24
Place Screws.....	25
Contour & Place First Rod	26
Reduce the First Rod.....	26
Rod Reduction - Rocker Method.....	27
Rod Reduction - Rod Reducer.....	28
Rod Reduction - Rod Reduction Tower	29
Provisionally Tighten Set Screws	30
Deformity Correction.....	31
Final Tightening.....	33
Reduction Screw	37

Hook Surgical Technique

Hook Site Preparation	38
Hook Placement.....	39
Rod Contouring.....	38
Rod Rotation.....	40
In-Situ Bending.....	41
Compression/Distracton.....	42
Stabilization Rod Placement.....	43

Cross Connector Technique

X-Link Placement.....	44
Fixed Cross Connector	45

Revision or Removal Techniques

Cross-Connector Removal.....	46
Set Screw Removal.....	47
Pedicle Screw Removal	48
Screw Extraction.....	49

Important Medical Information

Contra-Indications, Warnings,	52
Precautions	53

INDICATIONS

Outside of the United States - The **RESPONSE™ 5.5/6.0 Spine System** is intended for immobilization and stabilization of the posterior, non-cervical spine in skeletally mature patients as an adjunct to fusion for the following indications: degenerative disc disease (defined as back pain of discogenic origin with degeneration of the disc confirmed by history and radiographic studies), spondylolisthesis, trauma (i.e., fracture or dislocation), spinal stenosis, curvatures (i.e., scoliosis, kyphosis, or lordosis), tumor, pseudarthrosis, and/or failed previous fusion.

When used for posterior non-cervical pedicle screw fixation in pediatric patients, the **RESPONSE 5.5/6.0 Spine System** implants are indicated as an adjunct to fusion to treat adolescent idiopathic scoliosis. The **RESPONSE 5.5/6.0 Spine System** is intended to be used with autograft and/or allograft. Pediatric pedicle screw fixation is limited to a posterior approach.

When used in the European Union and the United Kingdom: When used for posterior non-cervical pedicle screw fixation in pediatric patients, the **RESPONSE 5.5/6.0 Spine System** implants are indicated as an adjunct to fusion to treat adolescent idiopathic scoliosis. The **RESPONSE 5.5/6.0 Spine Systems** are intended to be used with autograph and/or allograft. Pediatric pedicle screw fixation is limited to a posterior approach.

Inside the United States - The **RESPONSE 5.5/6.0 Spine System** is intended for immobilization and stabilization of the posterior, non-cervical spine in skeletally mature patients as an adjunct to fusion for the following indications: degenerative disc disease (defined as back pain of discogenic origin with degeneration of the disc confirmed by history and radiographic studies), spondylolisthesis, trauma (i.e., fracture or dislocation), spinal stenosis, curvatures (i.e., scoliosis, kyphosis, or lordosis), tumor, pseudarthrosis, and/or failed previous fusion.

When used for posterior non-cervical pedicle screw fixation in pediatric patients, the **RESPONSE 5.5/6.0 Spine System** implants are indicated as an adjunct to fusion to treat adolescent idiopathic scoliosis, neuromuscular scoliosis and congenital scoliosis. The **RESPONSE 5.5/6.0 Spine System** is intended to be used with autograft and/or allograft. Pediatric pedicle screw fixation is limited to a posterior approach.

SYSTEM FEATURES

The **RESPONSE 5.5/6.0 Spine System** includes a selection of biocompatible material and various implant designs, configurations and sizes to accommodate various surgical techniques. The primary features of the **RESPONSE 5.5/6.0mm Spine System** include the following:

- **unique set screw design** with proprietary square threads for better fixation and easy insertion to help reduce the ability to cross thread
- one of the **lowest profile 5.5/6.0mm** pedicle screws on the market
- unique one step, snap-on **rod reduction** instruments that complement the versatile rod reduction and coupled derotation options
- **versatility** in using 5.5mm or 6.0mm rod option in same low profile screw
- multiple screw options for **sacral fixation** (8mm and 9mm diameter screws)

5.5/6.0 Implant Classification

The **RESPONSE™ 5.5/6.0 Spine System** features the following pedicle screws:

- Polyaxial and Polyaxial Reduction Pedicle Screws
- Uniaxial and Uniaxial Reduction Pedicle Screws
- Fixed Pedicle Screws

Each pedicle screw size is designed with a unique color identifier as shown in the illustrations below.

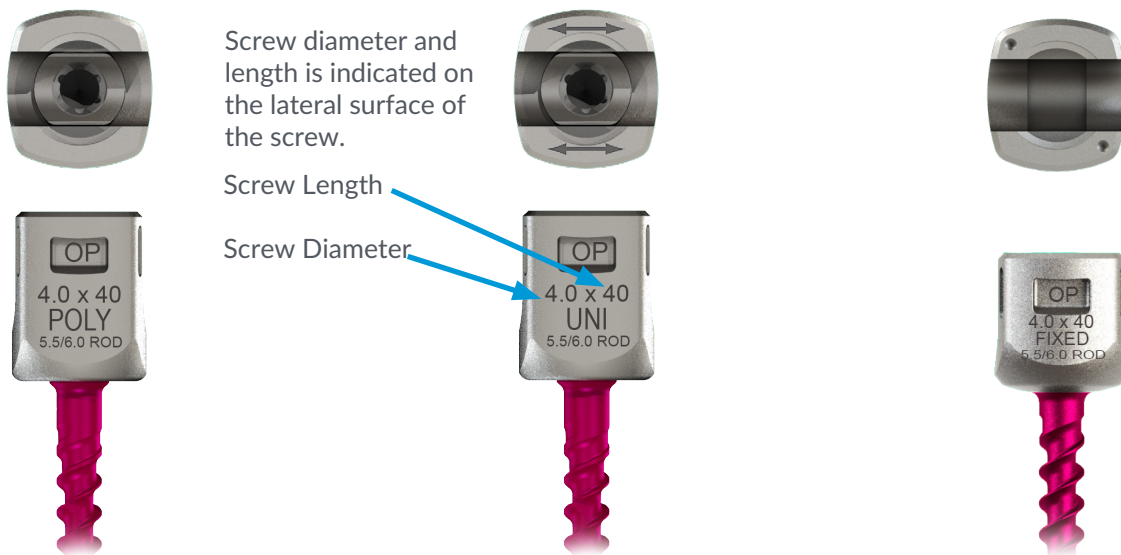

Polyaxial Screws are designated by an absence of arrows or divots on the proximal surface of the screw.

Uniaxial Screws are designated by two arrows on the proximal surface of the screw.

Fixed Screws are designated by a divot on the top left and bottom right corners on the proximal surface of the screw.



Polyaxial Reduction and Uniaxial Reduction Screws are designated by extended tabs which are removed following rod reduction.

5.5/6.0mm IMPLANTS

Polyaxial Pedicle Screws

5.5/6.0 Polyaxial Pedicle Screws	
00-1300-2420	4.0MM X 20MM
00-1300-2425	4.0MM X 25MM
00-1300-2430	4.0MM X 30MM
00-1300-2435	4.0MM X 35MM
00-1300-2440	4.0MM X 40MM
00-1300-2520	5.0MM X 20MM
00-1300-2525	5.0MM X 25MM
00-1300-2530	5.0MM X 30MM
00-1300-2535	5.0MM X 35MM
00-1300-2540	5.0MM X 40MM
00-1300-2545	5.0MM X 45MM
00-1300-2550	5.0MM X 50MM
00-1300-2555	5.0MM X 55MM
00-1300-2625	6.0MM X 25MM
00-1300-2630	6.0MM X 30MM
00-1300-2635	6.0MM X 35MM
00-1300-2640	6.0MM X 40MM
00-1300-2645	6.0MM X 45MM
00-1300-2650	6.0MM X 50MM
00-1300-2655	6.0MM X 55MM
00-1300-2730	7.0MM X 30MM
00-1300-2735	7.0MM X 35MM
00-1300-2740	7.0MM X 40MM
00-1300-2745	7.0MM X 45MM
00-1300-2750	7.0MM X 50MM
00-1300-2755	7.0MM X 55MM
00-1300-2760	7.0MM X 60MM
00-1300-2770	7.0MM X 70MM
00-1300-2780	7.0MM X 80MM
00-1300-2710	7.0MM X 100MM
00-1300-2850	8.0MM X 50MM
00-1300-2860	8.0MM X 60MM
00-1300-2870	8.0MM X 70MM
00-1300-2880	8.0MM X 80MM
00-1300-2810	8.0MM X 100MM
00-1300-2950	9.0MM X 50MM
00-1300-2960	9.0MM X 60MM
00-1300-2970	9.0MM X 70MM
00-1300-2980	9.0MM X 80MM
00-1300-2910	9.0MM X 100MM
Optional	
00-1300-2790	7.0MM X 90MM
00-1300-2890	8.0MM X 90MM
00-1300-2811	8.0MM X 110MM
00-1300-2990	9.0MM X 90MM
00-1300-2911	9.0MM X 110MM

5.5/6.0 Polyaxial Pedicle Screws	
00-1300-2420	4.0MM X 20MM
00-1300-2425	4.0MM X 25MM
00-1300-2430	4.0MM X 30MM
00-1300-2435	4.0MM X 35MM
00-1300-2440	4.0MM X 40MM
00-1300-2520	5.0MM X 20MM
00-1300-2525	5.0MM X 25MM
00-1300-2530	5.0MM X 30MM
00-1300-2535	5.0MM X 35MM
00-1300-2540	5.0MM X 40MM
00-1300-2545	5.0MM X 45MM
00-1300-2550	5.0MM X 50MM
00-1300-2555	5.0MM X 55MM
00-1300-2625	6.0MM X 25MM
00-1300-2630	6.0MM X 30MM
00-1300-2635	6.0MM X 35MM
00-1300-2640	6.0MM X 40MM
00-1300-2645	6.0MM X 45MM
00-1300-2650	6.0MM X 50MM
00-1300-2655	6.0MM X 55MM
00-1300-2730	7.0MM X 30MM
00-1300-2735	7.0MM X 35MM
00-1300-2740	7.0MM X 40MM
00-1300-2745	7.0MM X 45MM
00-1300-2750	7.0MM X 50MM
00-1300-2755	7.0MM X 55MM
00-1300-2760	7.0MM X 60MM
00-1300-2770	7.0MM X 70MM
00-1300-2780	7.0MM X 80MM
00-1300-2710	7.0MM X 100MM
00-1300-2850	8.0MM X 50MM
00-1300-2860	8.0MM X 60MM
00-1300-2870	8.0MM X 70MM
00-1300-2880	8.0MM X 80MM
00-1300-2810	8.0MM X 100MM
00-1300-2950	9.0MM X 50MM
00-1300-2960	9.0MM X 60MM
00-1300-2970	9.0MM X 70MM
00-1300-2980	9.0MM X 80MM
00-1300-2910	9.0MM X 100MM
Optional	
00-1300-2790	7.0MM X 90MM
00-1300-2890	8.0MM X 90MM
00-1300-2811	8.0MM X 110MM
00-1300-2990	9.0MM X 90MM
00-1300-2911	9.0MM X 110MM

5.5/6.0mm IMPLANTS

Uniaxial Pedicle Screws

5.5/6.0 Uniaxial Pedicle Screws	
00-1300-0420	4.0MM X 20MM
00-1300-0425	4.0MM X 25MM
00-1300-0430	4.0MM X 30MM
00-1300-0435	4.0MM X 35MM
00-1300-0440	4.0MM X 40MM
00-1300-0520	5.0MM X 20MM
00-1300-0525	5.0MM X 25MM
00-1300-0530	5.0MM X 30MM
00-1300-0535	5.0MM X 35MM
00-1300-0540	5.0MM X 40MM
00-1300-0545	5.0MM X 45MM
00-1300-0550	5.0MM X 50MM
00-1300-0555	5.0MM X 55MM
00-1300-0625	6.0MM X 25MM
00-1300-0630	6.0MM X 30MM
00-1300-0635	6.0MM X 35MM
00-1300-0640	6.0MM X 40MM
00-1300-0645	6.0MM X 45MM
00-1300-0650	6.0MM X 50MM
00-1300-0655	6.0MM X 55MM
00-1300-0730	7.0MM X 30MM
00-1300-0735	7.0MM X 35MM
00-1300-0740	7.0MM X 40MM
00-1300-0745	7.0MM X 45MM
00-1300-0750	7.0MM X 50MM
00-1300-0755	7.0MM X 55MM
00-1300-0760	7.0MM X 60MM
00-1300-0770	7.0MM X 70MM
00-1300-0780	7.0MM X 80MM
00-1300-0710	7.0MM X 100MM
	Optional
00-1300-0790	7.0MM X 90MM

5.5/6.0 Uniaxial Reduction Pedicle Screws	
00-1300-1420	4.0MM X 20MM
00-1300-1425	4.0MM X 25MM
00-1300-1430	4.0MM X 30MM
00-1300-1435	4.0MM X 35MM
00-1300-1440	4.0MM X 40MM
00-1300-1520	5.0MM X 20MM
00-1300-1525	5.0MM X 25MM
00-1300-1530	5.0MM X 30MM
00-1300-1535	5.0MM X 35MM
00-1300-1540	5.0MM X 40MM
00-1300-1545	5.0MM X 45MM
00-1300-1550	5.0MM X 50MM
00-1300-1555	5.0MM X 55MM
00-1300-1625	6.0MM X 25MM
00-1300-1630	6.0MM X 30MM
00-1300-1635	6.0MM X 35MM
00-1300-1640	6.0MM X 40MM
00-1300-1645	6.0MM X 45MM
00-1300-1650	6.0MM X 50MM
00-1300-1655	6.0MM X 55MM
00-1300-1730	7.0MM X 30MM
00-1300-1735	7.0MM X 35MM
00-1300-1740	7.0MM X 40MM
00-1300-1745	7.0MM X 45MM
00-1300-1750	7.0MM X 50MM
00-1300-1755	7.0MM X 55MM
00-1300-1760	7.0MM X 60MM
00-1300-1770	7.0MM X 70MM
00-1300-1780	7.0MM X 80MM
00-1300-1710	7.0MM X 100MM
	Optional
00-1300-1790	7.0MM X 90MM

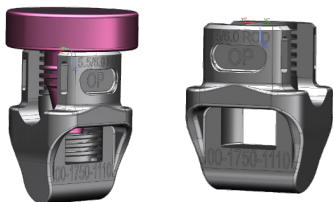

Screw Body Extensions	
00-1750-1110	5.5/6.0 Screw Body Extensions, 10mm
00-1750-1115	5.5/6.0 Screw Body Extensions, 15mm
00-1750-1120	5.5/6.0 Screw Body Extensions, 20mm

NOTE: Additional implants for Neuromuscular Indications are listed with auxillary steps on pages 50 & 51. These implants may not be available in all regions; contact your local OrthoPediatrics representative for availability and more information.

5.5/6.0mm IMPLANTS

Rod Options

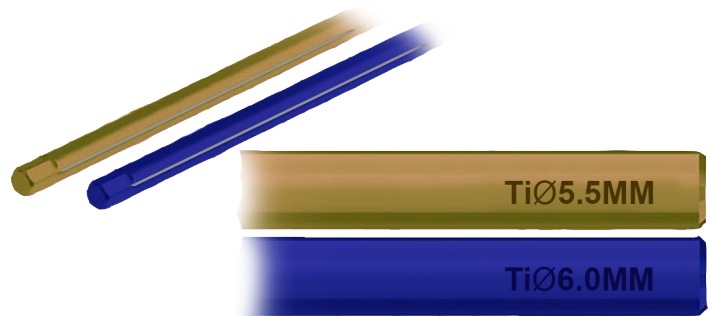
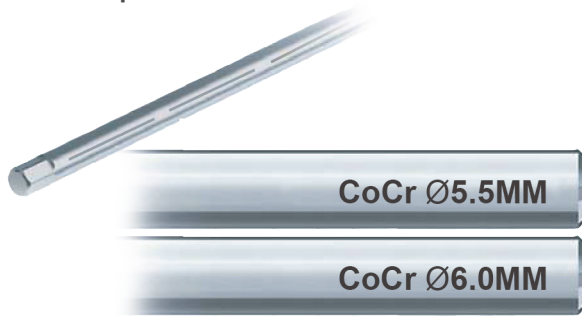

Cobalt Chrome rod material is indicated in two ways:

- etched dashed lines which run along the length of the rod
- etching opposite from the hex feature

Titanium Alloy rod material is indicated in three ways:

- etched straight line which runs along the length of the rod
- unique color identifier
- etching opposite from the hex feature

Cobalt Chrome Rod (CoCr)	
5.5mm x 500mm	00-1003-6001
6.0mm x 500mm	00-1300-6051
Optional	
5.5mm x 600mm	00-1003-6003
6.0mm x 600mm	00-1300-6061

Titanium Rod (Ti)	
5.5mm x 500mm	00-1300-5552
6.0mm x 500mm	00-1300-6052
Optional	
5.5mm x 600mm	00-1300-5562
6.0mm x 600mm	00-1300-6062

Rod Stiffness vs. Yield Point (Strength)*

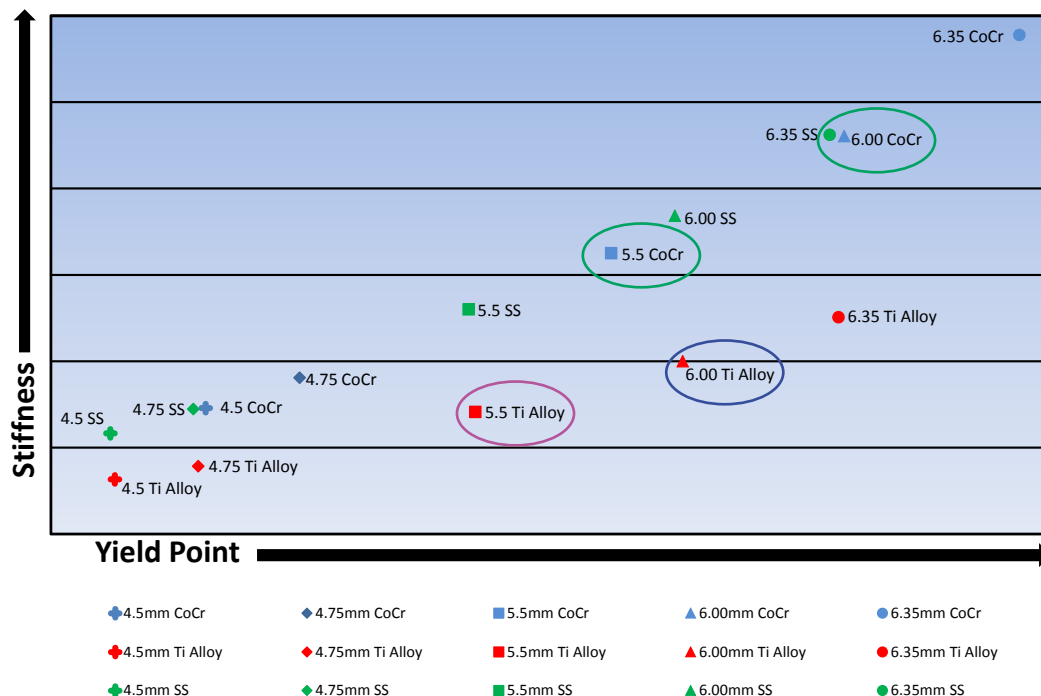

* based on rod material properties

5.5/6.0mm IMPLANTS

Connectors and Set Screws



Inline Connector, 20mm
00-1300-5720

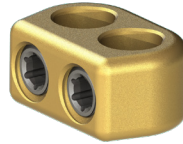

Wedding Band Connector
00-1300-6900



Large Set Screw
00-1003-4001



Domino Connector, 20mm
00-1300-6820

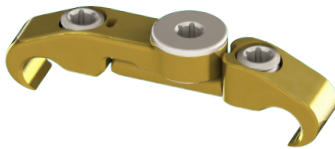

Used in:
- All Pedicle Screws
- Open Hooks



Open Lateral Connector	
20MM	00-1300-7020
30MM	00-1300-7030
40MM	00-1300-7040
50MM	00-1300-7050
60MM	00-1300-7060
70MM	00-1300-7070
80MM	00-1300-7080

Adjustable Cross Connector	
S	00-1300-3041
M	00-1300-3043
L	00-1300-3045
XL	00-1300-3047

Fixed Cross Connector	
14MM	00-1300-5014
16MM	00-1300-5016
18MM	00-1300-5018
20MM	00-1300-5020
22MM	00-1300-5022
24MM	00-1300-5024
26MM	00-1300-5026
28MM	00-1300-5028
30MM	00-1300-5030
32MM	00-1300-5032
34MM	00-1300-5034
36MM	00-1300-5036

5.5/6.0mm IMPLANTS

Hooks

	Open Pedicle Hook, 5.0mm	00-1300-3149
	Open Pedicle Hook, 6.5mm	00-1300-3150
	Open Pedicle Hook, 8.0mm	00-1300-3151
	Open Pedicle Hook, 9.5mm	00-1300-3153
	Open Pedicle Hook, 11.0mm	00-1300-3152
	Open Laminar Hook, 5.0mm, Narrow	00-1300-3249
	Open Laminar Hook, 6.5mm, Narrow	00-1300-3250
	Open Laminar Hook, 8mm, Narrow	00-1300-3251
	Open Laminar Hook, 9.5mm, Narrow	00-1300-3256
	Open Laminar Hook, 11mm, Narrow	00-1300-3252
	Open Laminar Hook, 5.0mm, Wide	00-1300-3257
	Open Laminar Hook, 6.5mm, Wide	00-1300-3253
	Open Laminar Hook, 8mm, Wide	00-1300-3254
	Open Laminar Hook, 9.5mm, Wide	00-1300-3258
	Open Laminar Hook, 11mm, Wide	00-1300-3255
	Open Thoracic Hook, 5.0mm, Narrow	00-1300-3259
	Open Thoracic Hook, 6.5mm, Narrow	00-1300-3260
	Open Thoracic Hook, 8.0mm, Narrow	00-1300-3261
	Open Thoracic Hook, 9.5mm, Narrow	00-1300-3262
	Open Thoracic Hook, 5.0mm, Wide	00-1300-3264
	Open Thoracic Hook, 6.5mm, Wide	00-1300-3265
	Open Thoracic Hook, 8.0mm, Wide	00-1300-3266
	Open Thoracic Hook, 9.5mm, Wide	00-1300-3267
	Open Thoracic Hook, 11.0mm, Wide	00-1300-3268
	Open Left Offset Thoracic Hook	00-1300-3300
	Open Right Offset Thoracic Hook	00-1300-3301
	Open Left Offset Lumbar Hook	00-1300-3302
	Open Right Offset Lumbar Hook	00-1300-3303
	Open Reduction Thoracic Hook, 5.0mm, Wide	00-1300-3401
	Open Reduction Thoracic Hook, 6.5mm, Wide	00-1300-3402
	Open Reduction Thoracic Hook, 8.0mm, Wide	00-1300-3403
	Open Reduction Thoracic Hook, 9.5mm, Wide	00-1300-3404
	Open Reduction Thoracic Hook, 11.0mm, Wide	00-1300-3405
	Open Reduction Left Offset Thoracic Hook	00-1300-3406
	Open Reduction Right Offset Thoracic Hook	00-1300-3407

INSTRUMENTS

Pedicle Prep/Screw Insertion



Pedicle Awl
01-1003-6020



Guide Wire, 490mm: 01-1300-5000



Lenke Probe, 2mm Straight
01-1003-6021



Feeler Probe, Small: 01-1003-6024
Feeler Probe, Large: 01-1003-6025



Lenke Probe, 2mm Curved
01-1003-6022



Taps



Thoracic Lenke Probe, 2mm Curved
01-1003-6016

3.0MM	01-1003-6026
4.0MM	01-1003-6027
5.0MM	01-1003-6028
6.0MM	01-1003-6029
7.0MM (Cannulated)	01-1300-0021
8.0MM (Cannulated)	01-1300-0022

INSTRUMENTS

Pedicle Prep/Screw Insertion



Detail of Pedicle Screw Driver

Pedicle Screw Driver (blue handle)	01-1003-6035
Reduction Pedicle Screw Driver (green handle)	01-1003-6036



Axial Handle, Fixed
01-1003-6299



Large Hudson Power Adapter
01-1003-5102



Axial Handle, Ratcheting
01-1003-6033



Screw Head Positioner
01-1003-6276



Palm Handle, Ratcheting
01-1003-6034



Fixed Ratcheting T-Handle
01-1600-0027

INSTRUMENTS

Pedicle Prep/Screw Insertion



Rod Template, 500mm
01-1003-6049



French Bender
01-1003-6055



Dual Action Rod Grippers
5.5mm Rod Grippers (black grips): 01-1003-6290
6.0mm Rod Grippers (green grips): 01-1300-0014

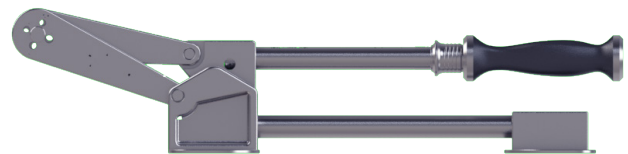

Rod Cutter
01-1300-0015

INSTRUMENTS

Pedicle Prep/Screw Insertion



In-Situ Benders	
5.5mm, Left	01-1003-6057
5.5mm, Right	01-1003-6291
6.0mm, Left*	01-1300-0010
6.0mm, Right*	01-1300-0011

*6.0mm In-Situ Benders feature **green** handles



Coronal Benders	
5.5mm, Left	01-1003-6215
5.5mm, Right	01-1003-6216
6.0mm, Left*	01-1300-0013
6.0mm, Right*	01-1300-0012

*6.0mm Coronal Benders feature **green** handles



Compressors	
Small	01-1003-6078
Medium	01-1003-6292
Large	01-1003-6217

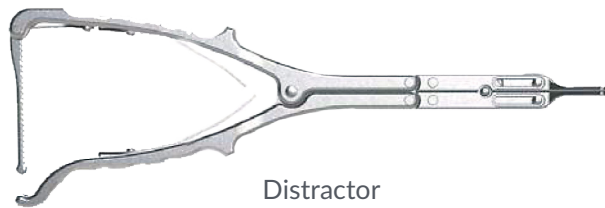

Distractor
01-1003-6079



Rod Pusher
01-1003-6069



Rocker
01-1003-6071

INSTRUMENTS

Rod Reduction & Screw Tightening



Driver, Short: 01-1003-5100
Driver, Long*: 01-1003-5101

*Long is intended to be used with Extension Handles (01-1003-5051)



Final Torque Large Set Screw Driver
01-1300-9100



T-30 Large Set Screw Driver
01-1003-9130

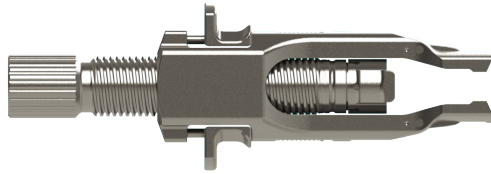

Rod Reducer
01-1003-5000



Mini Rod Reducer
01-1300-6000



Final Torque Driver, Short
01-1102-1055



Counter Torque Tube, Short
Counter Torque
01-1300-0028



Counter Torque Tube
01-1003-6140

INSTRUMENTS

X-Link



X-Link Bender, Adjustable 01-1300-0017
X-Link Bender, Left 01-1300-0018



X-Link Counter Torque Tube
01-1003-6166

Multi Segment Derotation Instruments



Extension Handles
01-1003-5051

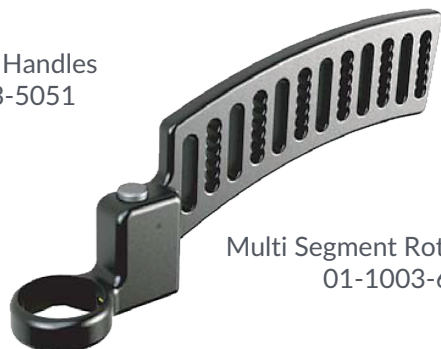

Multi Segment Rotation Handle
01-1003-6100



Multi Segment Rotation Pin, Long
01-1003-6116



Multi Segment Rotation Pin, Short
01-1003-6117



Multi Segment Rotation Pin, Extra Long
01-1003-6305

INSTRUMENTS

Final Tightening

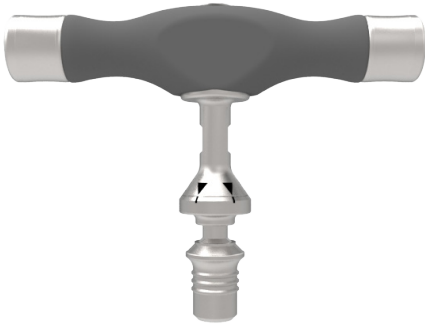

Set Screw Torque Limiter
Gray T-Handle, 13 N-m*
01-1300-4000

*a sleeve is included on each T-handle indicating the date in which recalibration is required.



X-Link Torque Limiter
Green T-Handle, 58 in-lbs*
01-1003-6167

*a sleeve is included on each t-handle indicating the date in which recalibration is required.



Manual Single Use Set Screw Torque Limiter
Dark Gray Sleeve; 14 N-m
803-003



Manual Single Use Torque Limiter
Blue Sleeve; 7 N-m
803-001

INSTRUMENTS

Hooks



Straight Hook Holder
01-1003-6150



Straight Closed Hook Holder
01-1003-6152



Lateral Hook Holder
01-1003-6297



Straight Offset Hook Holder
01-1003-6298



Hook Pusher, Hook Mating
01-1003-6158

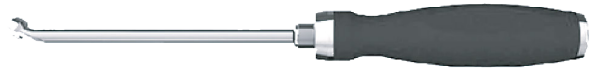

Hook Pusher, C-shaped
01-1003-6159



Small Set Screw Starter
01-1003-6273



T-20 Small Set Screw Driver
01-1003-6165



Straight Transverse Hook Trial
01-1003-3154



Straight Laminar Hook Trial
01-1003-3155



Straight Pedicle Hook Trial
01-1003-3156

Hook Description	5.5mm System Item Number
Open Pedicle Hook, 5.0mm	00-1003-3149
Open Pedicle Hook, 6.5mm	00-1003-3150
Open Pedicle Hook, 8.0mm	00-1003-3151
Open Pedicle Hook, 9.5mm	00-1003-3153
Open Pedicle Hook, 11.0mm	00-1003-3152
Open Laminar Hook, 5.0mm, Narrow	00-1003-3249
Open Laminar Hook, 6.5mm, Narrow	00-1003-3250
Open Laminar Hook, 8mm, Narrow	00-1003-3251
Open Laminar Hook, 9.5mm, Narrow	00-1003-3256
Open Laminar Hook, 11mm, Narrow	00-1003-3252
Open Laminar Hook, 5.0mm, Wide	00-1003-3257
Open Laminar Hook, 6.5mm, Wide	00-1003-3253
Open Laminar Hook, 8mm, Wide	00-1003-3254
Open Laminar Hook, 9.5mm, Wide	00-1003-3258
Open Laminar Hook, 11mm, Wide	00-1003-3255
Open Thoracic Hook, 5.0mm, Narrow	-
Open Thoracic Hook, 6.5mm, Narrow	00-1003-3260
Open Thoracic Hook, 8.0mm, Narrow	00-1003-3261
Open Thoracic Hook, 9.5mm, Narrow	00-1003-3262
Open Thoracic Hook, 11.0mm, Narrow	-
Open Thoracic Hook, 5.0mm, Wide	-
Open Thoracic Hook, 6.5mm, Wide	00-1003-3265
Open Thoracic Hook, 8.0mm, Wide	00-1003-3266
Open Thoracic Hook, 9.5mm, Wide	00-1003-3267
Open Thoracic Hook, 11.0mm, Wide	-
Open Left Offset Thoracic Hook	00-1003-3300
Open Right Offset Thoracic Hook	00-1003-3301

Hook Description	5.5mm System Item Number
Open Reduction Thoracic Hook, 5.0mm, Wide	-
Open Reduction Thoracic Hook, 6.5mm, Wide	-
Open Reduction Thoracic Hook, 8.0mm, Wide	-
Open Reduction Thoracic Hook, 9.5mm, Wide	-
Open Reduction Thoracic Hook, 11.0mm, Wide	-
Open Reduction Left Offset Thoracic Hook	-
Open Reduction Right Offset Thoracic Hook	-
Closed Pedicle Hook, 5.0mm	00-1003-3099
Closed Pedicle Hook, 6.5mm	00-1003-3100
Closed Pedicle Hook, 8mm	00-1003-3101
Closed Pedicle Hook, 9.5mm	00-1003-3103
Closed Pedicle Hook, 11mm	00-1003-3102
Closed Laminar Hook, 5.0mm Narrow	00-1003-3199
Closed Laminar Hook, 6.5mm, Narrow	00-1003-3200
Closed Laminar Hook, 8mm, Narrow	00-1003-3201
Closed Laminar Hook, 9.5mm Narrow	00-1003-3206
Closed Laminar Hook, 11mm, Narrow	00-1003-3202
Closed Laminar Hook, 5.0mm Wide	00-1003-3207
Closed Laminar Hook, 6.5mm, Wide	00-1003-3203
Closed Laminar Hook, 8mm, Wide	00-1003-3204
Closed Laminar Hook, 9.5mm Wide	00-1003-3208
Closed Laminar Hook, 11mm, Wide	00-1003-3205
Open Left Offset Lumbar Hook	00-1003-3302
Open Right Offset Lumbar Hook	00-1003-3303

NOTE: 5.5mm ONLY Available Outside the United States.

Screw Description	5.5mm Uniaxial Screw	5.5mm Polyaxial Screw
4.0mm x 20mm	00-1003-4318	00-1003-4066
4.0mm x 25mm	00-1003-4319	00-1003-4067
4.0mm x 30mm	00-1003-4320	00-1003-4068
4.0mm x 35mm	00-1003-4321	00-1003-4069
4.0mm x 40mm	00-1003-4322	00-1003-4070
5.0mm x 20mm	00-1003-4351	00-1003-4099
5.0mm x 25mm	00-1003-4352	00-1003-4100
5.0mm x 30mm	00-1003-4353	00-1003-4101
5.0mm x 35mm	00-1003-4354	00-1003-4102
5.0mm x 40mm	00-1003-4355	00-1003-4103
5.0mm x 45mm	00-1003-4356	00-1003-4104
5.0mm x 50mm	00-1003-4357	00-1003-4105
5.0mm x 55mm	00-1003-4358	00-1003-4106
6.0mm x 30mm	00-1003-4387	00-1003-4135
6.0mm x 35mm	00-1003-4388	00-1003-4136
6.0mm x 40mm	00-1003-4389	00-1003-4137
6.0mm x 45mm	00-1003-4390	00-1003-4138
6.0mm x 50mm	00-1003-4391	00-1003-4139
6.0mm x 55mm	00-1003-4392	00-1003-4140
7.0mm x 35mm	00-1003-4422	00-1003-4170
7.0mm x 40mm	00-1003-4423	00-1003-4171
7.0mm x 45mm	00-1003-4424	00-1003-4172
7.0mm x 50mm	00-1003-4425	00-1003-4173
7.0mm x 55mm	-	-
7.0mm x 60mm	00-1003-4427	00-1003-4175
7.0mm x 70mm	00-1003-4429	00-1003-4177
7.0mm x 80mm	00-1003-4431	00-1003-4179

5.5mm Connectors and Set Screws



Fixed Cross Connector	
14mm	00-1003-3086
16mm	00-1003-3087
18mm	00-1003-3088
20mm	00-1003-3089
22mm	00-1003-3090
24mm	00-1003-3091
26mm	00-1003-3092
28mm	00-1003-3093
30mm	00-1003-3094
32mm	00-1003-3095
34mm	00-1003-3096
36mm	00-1003-3097



Closed Lateral Connector	
20mm	00-1003-3065
30mm	00-1003-3066
40mm	00-1003-3067
60mm	00-1003-3068



Adjustable Cross Connector	
XS	00-1003-3041
S	00-1003-3043
M	00-1003-3045
L	00-1003-3047
XL	00-1003-3049



Inline Connector
00-1003-3050



Wedding Band
Connector
00-1003-3055



Set Screw, Small*
00-1003-3012



Domino Connector
00-1003-3054

*5.5mm System ONLY

Used In: Closed Hooks, Lateral, Inline,
Wedding Band, & Domino Connectors

NOTE: 5.5mm ONLY Available Outside the United States.

PEDICLE SCREW SURGICAL TECHNIQUE



Figure 1



Figure 2



Perform Thoracic Facetectomy

Clean the facet joints and use rongeurs, chisels or bone scalpels to perform a partial inferior articular process osteotomy to enhance visualization.

Remove 3mm to 5mm of the inferior facet and denude the articular cartilage on the superior facet, except for the lowest vertebra to be instrumented. This will allow for the intraoperative localization of the thoracic pedicle screw starting points and enhance fusion.

Anatomic starting points vary by the posterior elements that can be observed intraoperatively. These include the transverse process, the lateral portion of the pars interarticularis, and the base of the superior articular process.

After a thorough exposure, use as much anatomic information as possible by starting with a neutral, non-rotated vertebra.

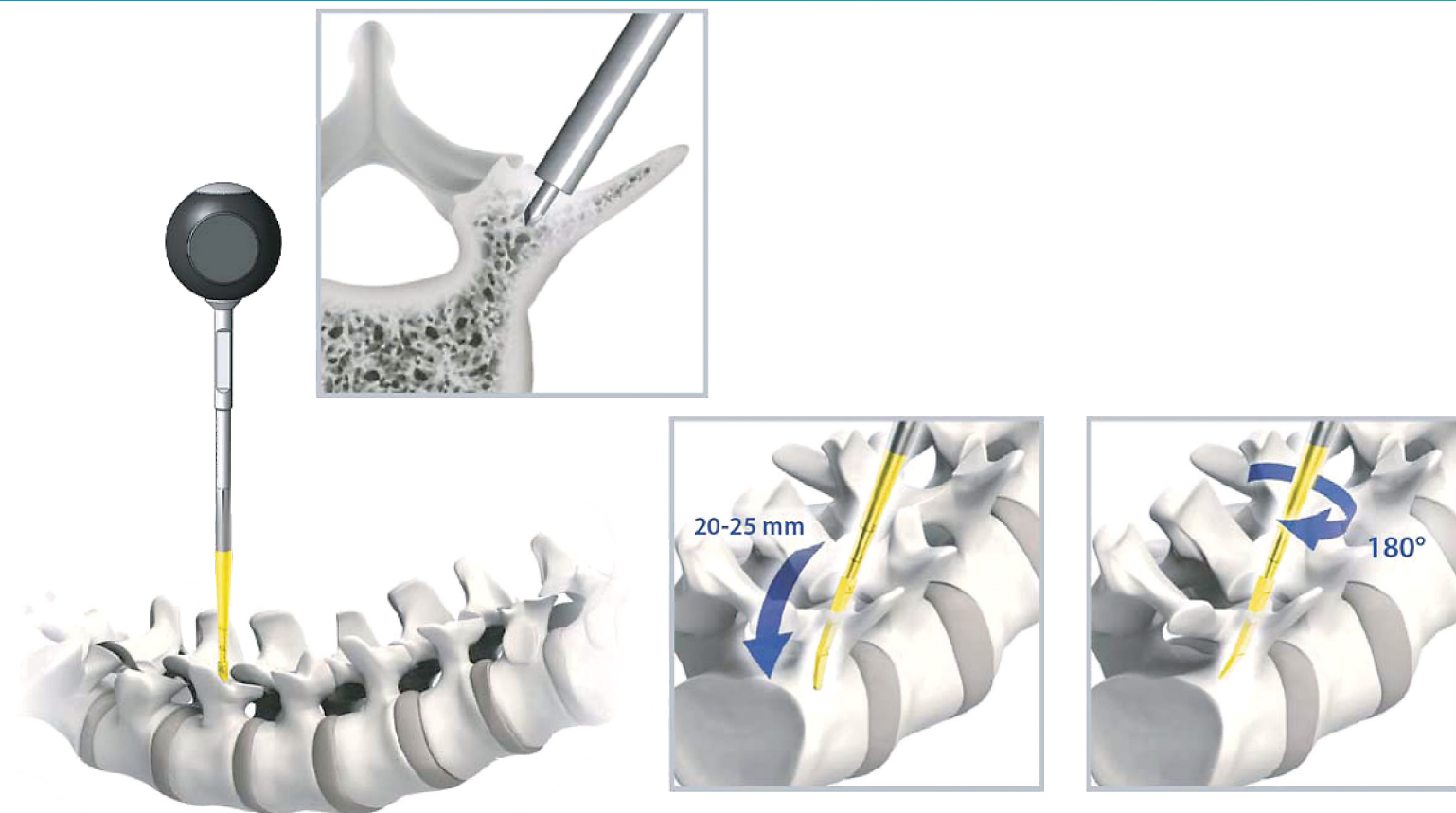

Prepare Pedicles

Create a 3mm deep posterior cortical breach with the Pedicle Awl or burr. Gentle twisting of the handle with light pressure is the safest way to advance the awl. A pedicle blush may be visualized suggesting entrance into the cancellous bone at the base of the pedicle.

Occasionally when preparing small pedicles located at the apex of the curve, the blush will not be evident due to the limited intrapedicular cancellous bone. In this case, use the straight or curved Lenke Probe to search in the cortical breach for the soft, funnel-shaped cancellous bone, which indicates the entrance to the pedicle. The tip should be pointed laterally to avoid perforation of the medial cortex. The feeler probe can be used to find the pedicle with minimal risk of wall penetration. Small taps, like a pile driver can safely advance the probe.

Grip the side of the handle to avoid applying too much ventral pressure. Insert the tip approximately 20mm to 25mm. Orient the probe so that the flat surface of the probe is in the same plane as the

curve of the pedicle, then remove the probe to reorient it so that the tip points medially.

NOTE: Take care to ensure the orientation of the probe is correct in order to avoid damage to the pedicle.

Carefully place the probe into the base of the prior hole and use the instrument markings to advance the probe to the desired depth. Rotate the probe 180° to ensure adequate room for the screw.

At each of these three steps, remove the awl and confirm intrapedicular position with the feeler probe.

CAUTION: The Small Lenke Probe is intended for use in pediatric cases where an exceptionally small pedicle is present. Due to the narrow shaft of the instrument, the probe should be introduced with care to ensure that the tip is not fractured. If additional force is required, it is recommended to use the standard probe.

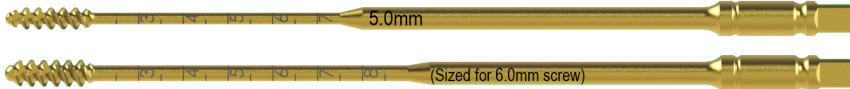
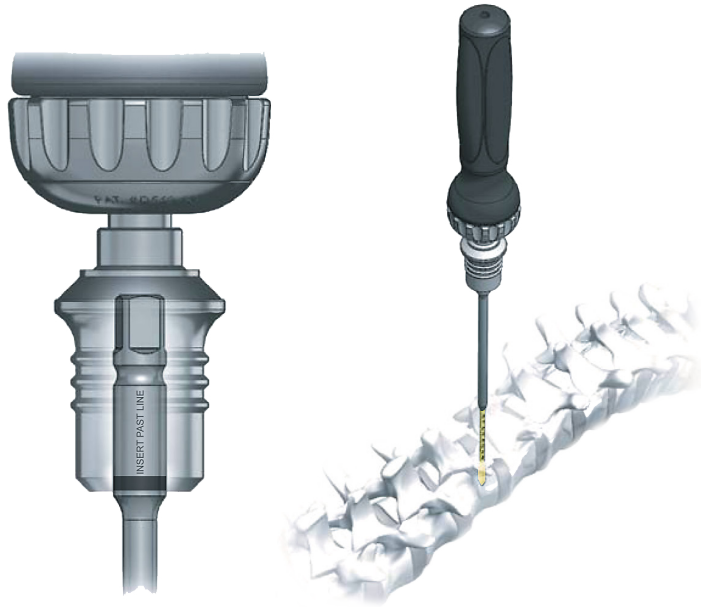

Tap Sizing	
Screw Size	Tap Size
4mm Screw	3mm Tap
5mm Screw	4mm Tap
6mm Screw	5mm Tap
7mm Screw	6mm Tap
8mm Screw	7mm Tap
9mm Screw	8mm Tap

Prepare Pedicles

Check to ensure that only blood is coming out of the pedicle and maintain proper hemostasis. Advance the Feeler Probe to the base (floor) of the hole to confirm five distinct bony borders: a floor and four walls (medial, lateral, superior, and inferior). Give special care to the first 10 to 15mm of the tract. When necessary, place bone wax or other hemostatic agent in the pedicle hole to limit bleeding, then reposition the probe with a more appropriate trajectory. Utilize fluoroscopy to verify correct pedicle preparation.

WARNING: Insufficient room for the screw will violate spinal cord space.

WARNING: Use CAUTION when utilizing power throughout surgery. Ensure the drill or reamer is on a low rate of speed to maintain control.

Next, undertap the pedicle 1mm less than desired screw size using a handle or power. Taps are marked according to their actual dimensions to aid in the selection of the proper size. Palpate the tapped pedicle tract with a flexible Feeler Probe to feel for the presence of threads after tapping.

CAUTION: Ensure appropriate size screw is selected prior to tapping. Selection of incorrect screw size can lead to damage to pedicle.

CAUTION: Use care when utilizing Taps to avoid injury to both patient and physician.

- NOTE:** When assembling Taps to the handle, ensure that the tap is fully seated in the handle. The black line on the shaft will be fully covered when properly seated.
- NOTE:** Etching on the taps indicate the screw size and corresponding Tap sizes.
- NOTE:** When utilizing guide wires with cannulated Taps, ensure there is no damage to the wire. Damage may result in complications with the patient or interactions with other mating devices.

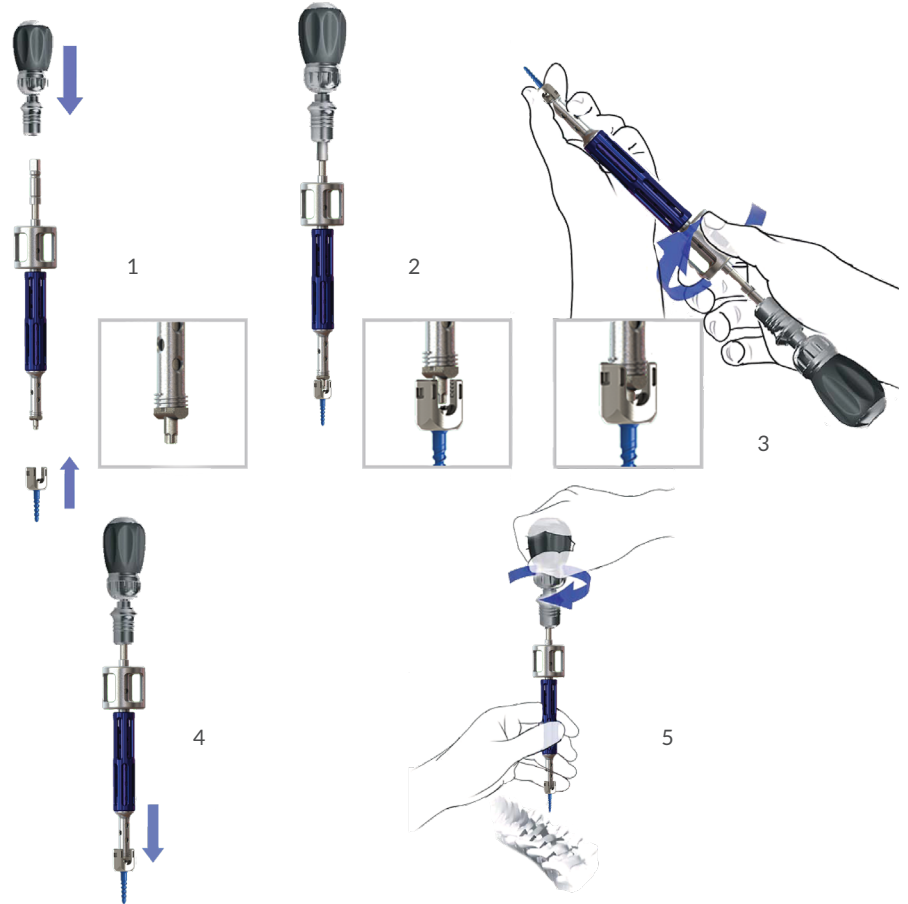
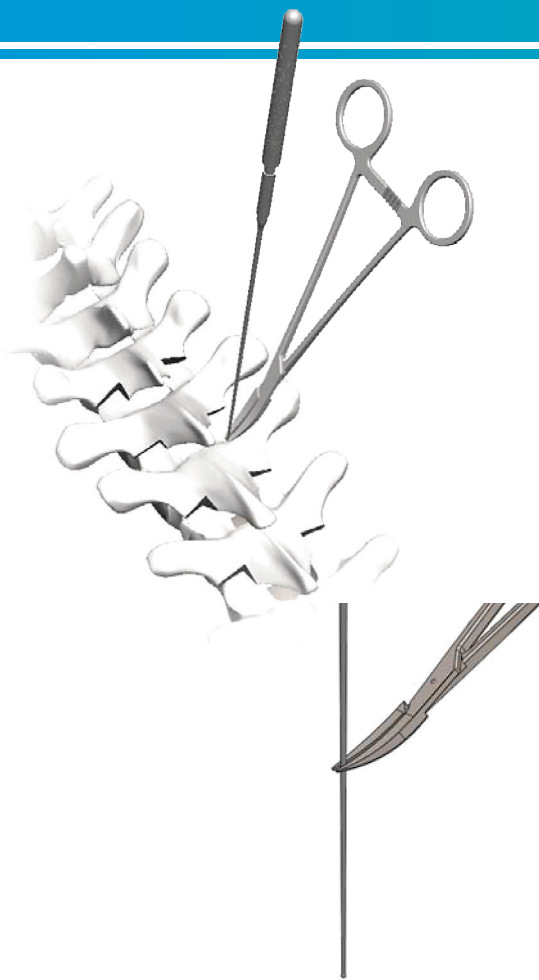

Prepare Pedicles

Clamp a hemostat to the exposed Feeler Probe to measure the length of the hole. Select the appropriate screw length by both preoperative measurement and intraoperative observation.

- 1 **NOTE:** Reference the System Overview section to ensure correct screw is selected prior to driver application.
- 2 **NOTE:** Ensure all steps are followed for proper assembly of screw and driver to avoid disengagement during application.
- 3 **NOTE:** Pedicle Screws can be inserted under power by attaching the power adapter (01-1003-5102) to the screwdriver.

Pedicle Screw Driver Application

- 1 Attach handle to Poly Driver, select screw for insertion.
- 2 Place the hexalobe tip of the driver into the screw. Engage the hex with the driver tip.
- 3 Turn the threading knob to thread the driver to the screw.
- 4 Engage the rotation sleeve by pushing it down into the head of the screw.
The tab feature keeps the screw from disengaging from the driver during screw insertion.
- 5 Turn the driving knob while holding the shaft of the Poly Driver assembly to advance the screw down the pedicle.

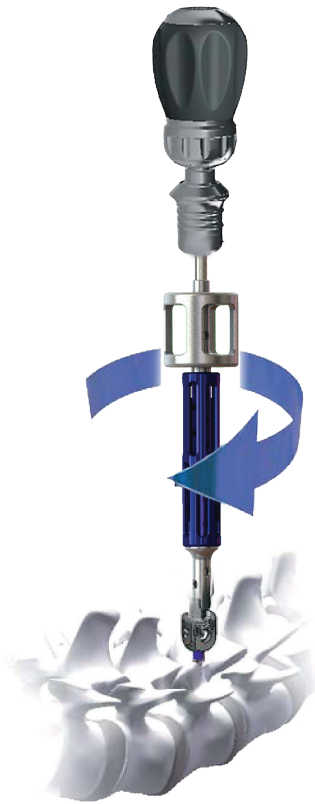

Figure 1: Advance the pedicle screw.

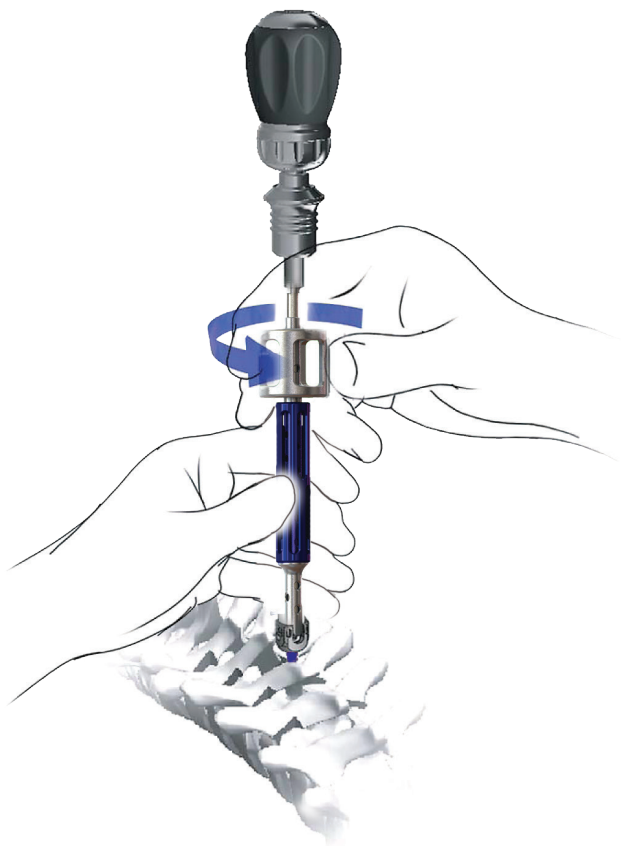

Figure 2: Disengage the driver from the screw.

Place Screws

Slowly advance the screw down the pedicle to ensure proper tracking (Figure 1).

To disengage the driver from the screw, turn the threading knob counterclockwise, then gently rock the driver to disengage the tip of the hex from the screw (Figure 2).

Screws should be placed at every segment that allows free passage of a screw on the correction side and every third or fourth level on the supportive side. Insert at least two screws at the proximal and distal end of the supportive side. As needed, more screws are placed for greater construct rigidity. At this time, screws may be interchanged as needed. Screws should be checked radiographically at this time to ensure intraosseous screw placement.

Scoliotic pedicles may be too narrow to cannulate, especially at the concave apex. Alternate fixation such as hooks, wires, bands, or tapes can be used.

NOTE: Following screw insertion, utilize the screw head positioner to ensure proper tulip head alignment in preparation for rod placement.

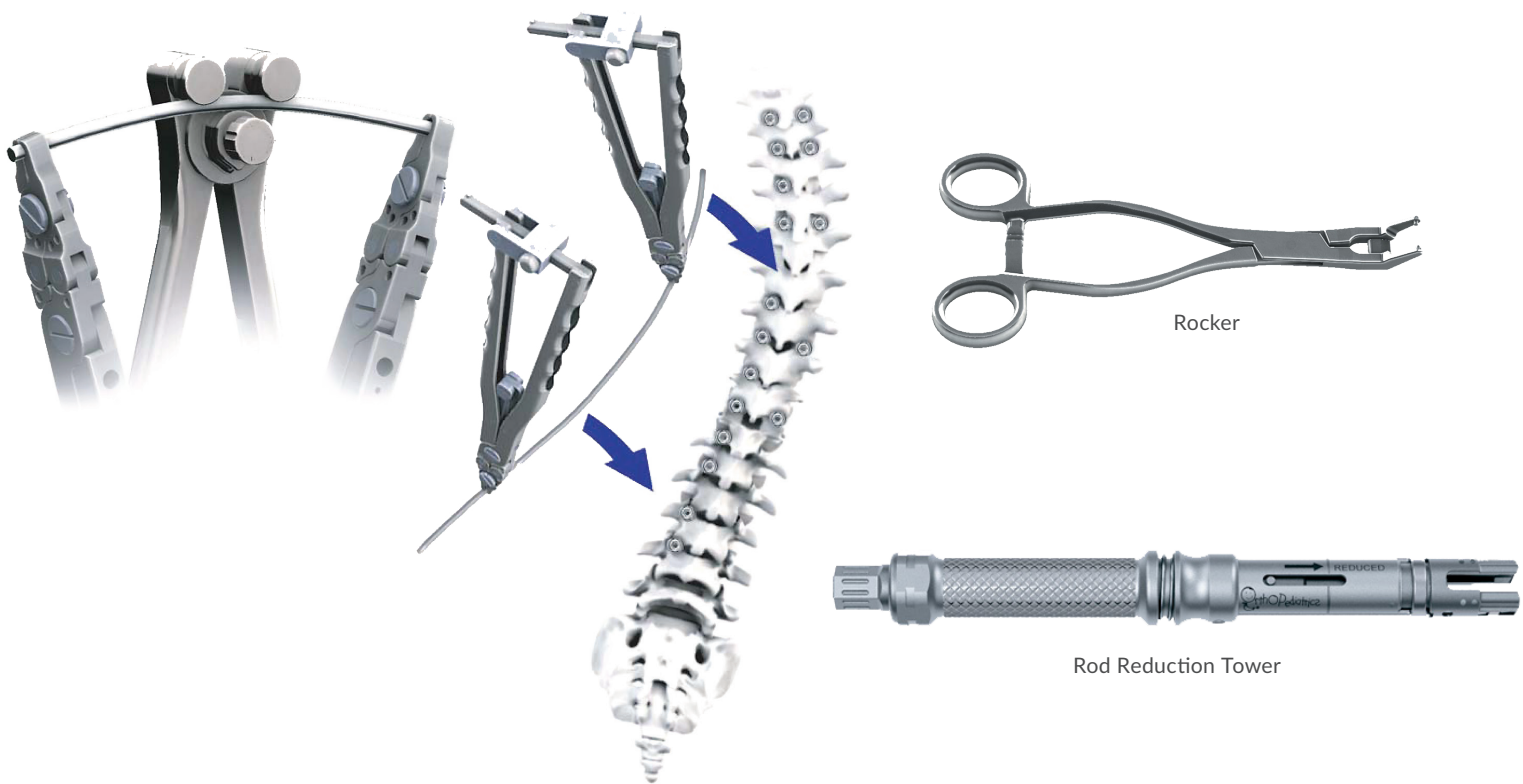

Contour & Place the First Rod

Before placing rods, confirm screw placement with 2D or 3D fluoroscopy.

Triggered EMG's may be performed at this stage.

Once correct screw placement has been verified radiographically, measure and contour rods in the sagittal and coronal planes. Clamping the rod with Rod Grippers at both ends helps prevent the rod from rotating during contouring.

NOTE: Ensure the appropriate size rod and material is selected. Do not rebend rods.

Reduce the First Rod

For non-hyperkyphotic deformities, depending upon surgeon preference, the rod may be placed on the concave side first. The contoured rod is placed into the previously placed screws. There are multiple options and instruments that can facilitate seating the rod into the saddle of the implant.

NOTE: Care should be taken with any of the following reduction methods. Improper instrument use may loosen implants or damage the residual facets and other bony anatomy.

Two instruments are used to facilitate fully seating the rod into the saddle: the Rocker and the Rod Reduction Tower,

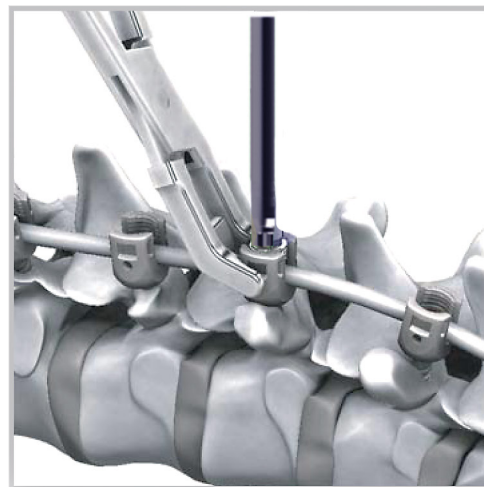
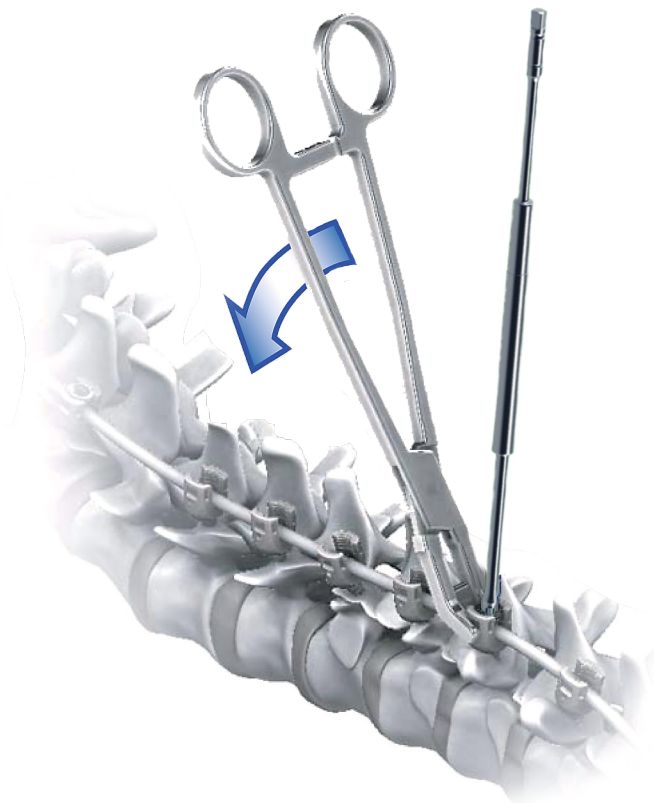

Rod Reduction – Rocker Method

Use of the Rocker is an effective method for reducing (or seating) the rod into the implant when only a slight height difference exists between the rod and the implant saddle.

To reduce the rod using the Rocker method, grasp the sides of the implant with the rocker cam above the rod. Lever the Rocker backwards over the rod to seat the rod into the saddle of the implant. Use the Large Set Screw Driver to place a set screw and provisionally tighten.

NOTE: To avoid cross threading of the set screw, it is advised to turn the set screw counterclockwise until a click is felt, ensuring that the set screw is lined up correctly. Then proceed with clockwise tightening of the set screw.

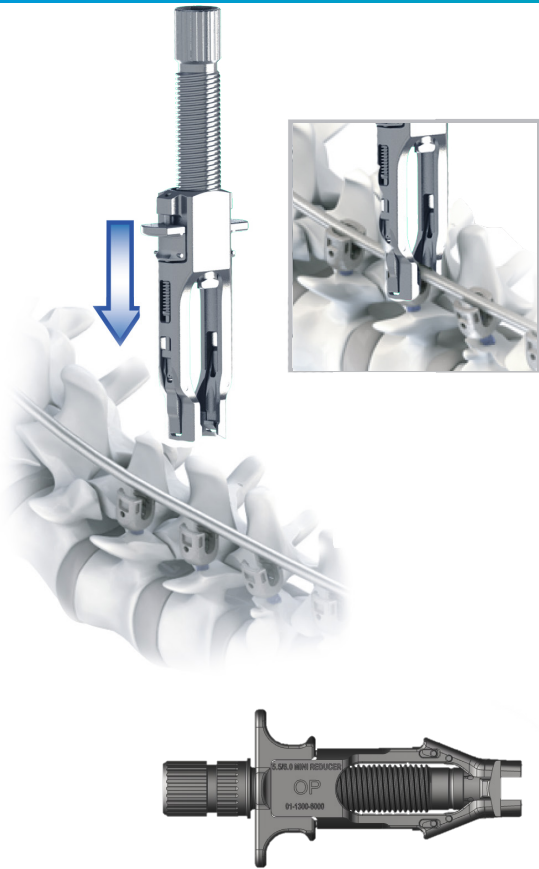

Rod Reduction – Rod Reducer

- 1 Insert and affix Rod Reducer by pushing down over the top of the screw head.
- 2 To reduce the Rod, use the hex adapter and axial ratcheting handle to turn the hexagonal knob clockwise.

NOTE: The 01-1300-6000 Mini Rod Reducer may be used as an alternative to the 01-1003-5000 Rod Reducer to reduce the rod. Steps 1 & 2 are still applicable.

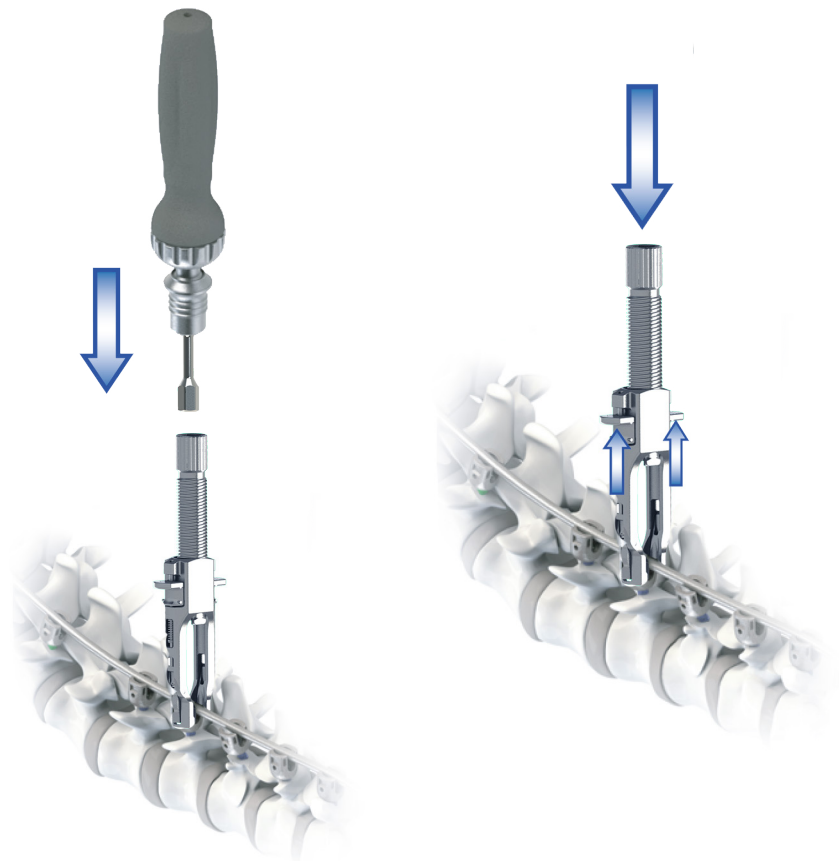

Rod Reducer Removal

See page 30 for instructions on provisionally tightening set screws. After the rod has been reduced and the set screw has been provisionally tightened, the Rod Reducer may be removed from the screw head. Turn the knob counter clockwise a few turns and then place downward pressure on the knob and pull up on the release tabs to disengage from the screw head.

WARNING: The Rod Reducer does not fully seat the rod.

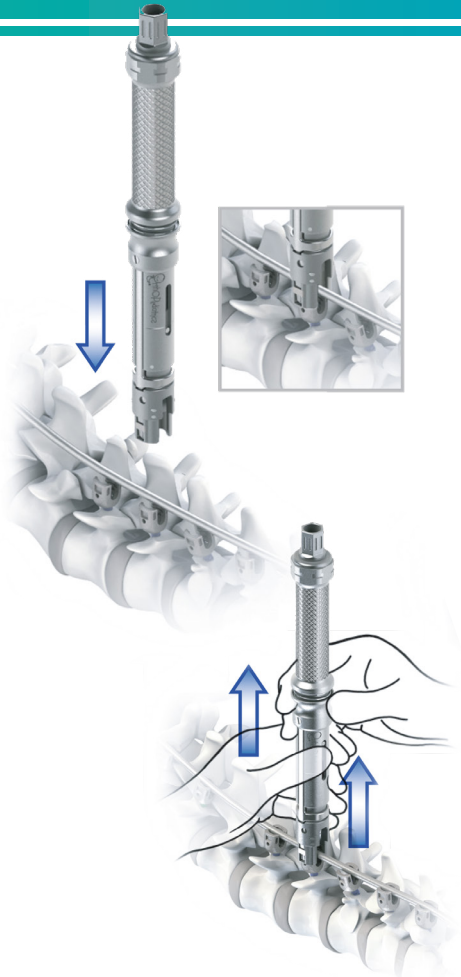

Rod Reduction – Rod Reduction Tower

- 1 Insert and affix Rod Reduction Tower by pushing down over the top of the screw head.
- 2 To reduce the Rod, use the hex adapter and axial ratcheting handle to turn the hexagonal knob clockwise.

NOTE: When the black line is visible, it identifies the rod is fully reduced.

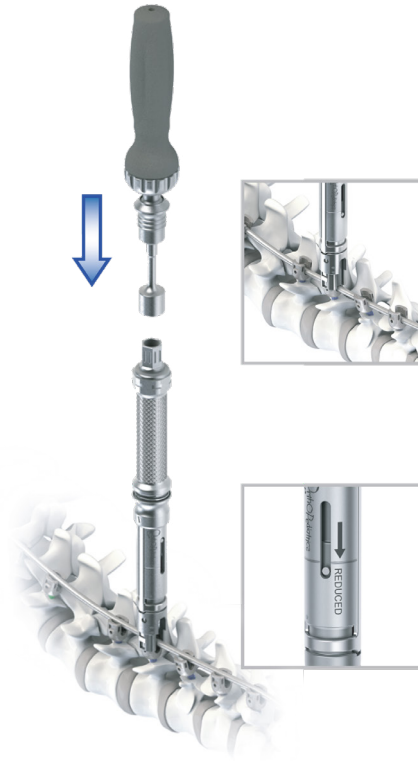

Tower Removal

See page 30 for instructions on provisionally tightening set screws. After the rod has been reduced and the set screw has been provisionally tightened, the Rod Reduction Tower may be removed from the screw head. Turn the hexagonal knob counter clockwise a few turns, then pull up on the medial collar to disengage from the screw head.

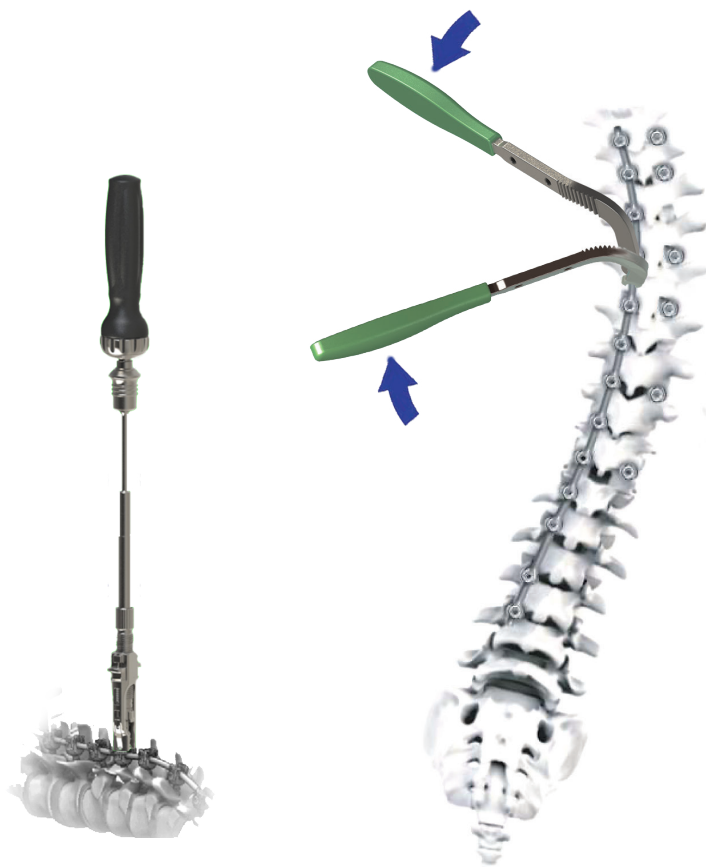

Provisionally Tighten Set Screws

- 3 Capture the appropriate set screw onto the hexalobe feature of the Large Set Screw Driver.
- 4 Use the Large Set Screw Driver to introduce the Set Screw. Send the Set Screw down the Rod Reducer until it bottoms out on the screw threads. To avoid cross threading of the Set Screw, turn the set screw counterclockwise until a click is felt, ensuring that the set screw is lined up correctly. Then proceed with clockwise tightening of the Set Screw.

Deformity Correction – Straighten Rod via Rotation and/or Coronal Bending

Keep the set screws loose (or only locked at one end), then slowly straighten the concave rod with the Coronal Benders. Perform each straightening of the concave rod over a pedicle screw. Several passes may be required.

NOTE: To avoid cross threading of the set screw, it is advised to turn the set screw counterclockwise until a click is felt, ensuring that the set screw is lined up correctly. Then proceed with clockwise tightening of the set screw.

See pages 25-29 to reference rod reduction and contouring. At this point of the surgery part of the correction has been achieved, mainly due to translation maneuvers used when inserting the rod. Further correction can be accomplished with rod rotation and/or coronal bending, depending on the type and stiffness of the curve, and completed with compression/distraction maneuvers.

NOTE: If using a 5.5mm rod, the black-handled Coronal Benders and In-Situ Benders should be used. If using a 6.0mm rod, the green-handled Coronal Benders and In-Situ Benders should be used.



Figure 1: Rod rotation for final positioning



Figure 2: Compression and distraction of rod

Deformity Correction

Rod Rotation

Once the contoured rod and all of the set screws have been placed, the rod is ready to be rotated into its final position (Figure 1). The rotation must be done slowly in order to prevent rapid neurologic changes and/or injury to the spinal cord. The rotation is done using two rod-grippers. It is important to monitor the interval hooks, which tend to back out during rod rotation.

NOTE: If using a 5.5mm rod, the 5.5mm rod-grippers should be used. If using a 6.0mm rod, the 6.0mm rod-grippers should be used.

Compression & Distraction

Tighten the apical set screws. Compression or distraction may be performed at this time (Figure 2). Watch the screw/bone interface with all correction maneuvers.

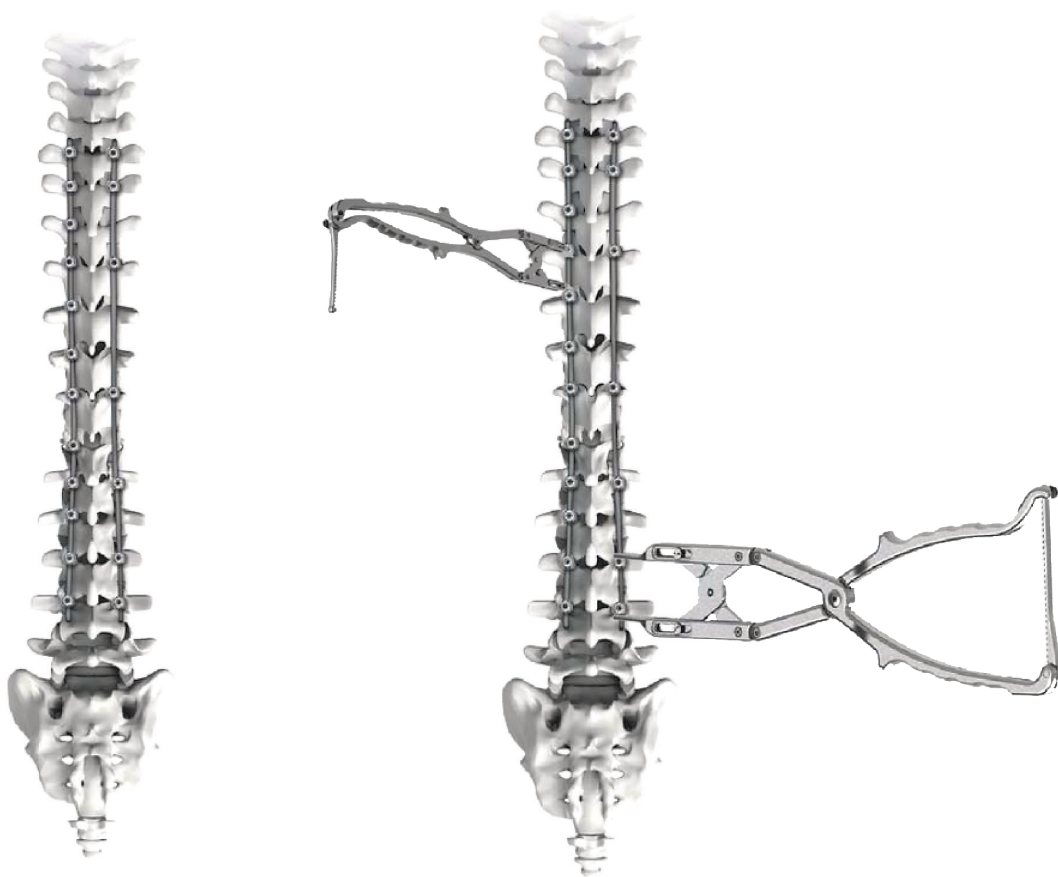

Deformity Correction – Place the Stabilizing Rod

Following placement of the second rod and set screws, convex compressive forces are placed on the segments using the Parallel Compressor to horizontalize the lowest instrumented vertebra and mildly compress the convexity of the deformity. It is preferred that compression be released just prior to final tightening. This technique will help ensure that the implant head and rod are normalized to one another and thus allow for the rod to be fully seated in the implant head during the final tightening step.

Perform sensory and motor evoked potential monitoring for the early detection of a spinal cord deficit during surgical manipulation of the spine.

Verify fixation with A/P and lateral x-rays to confirm spinal correction and alignment.

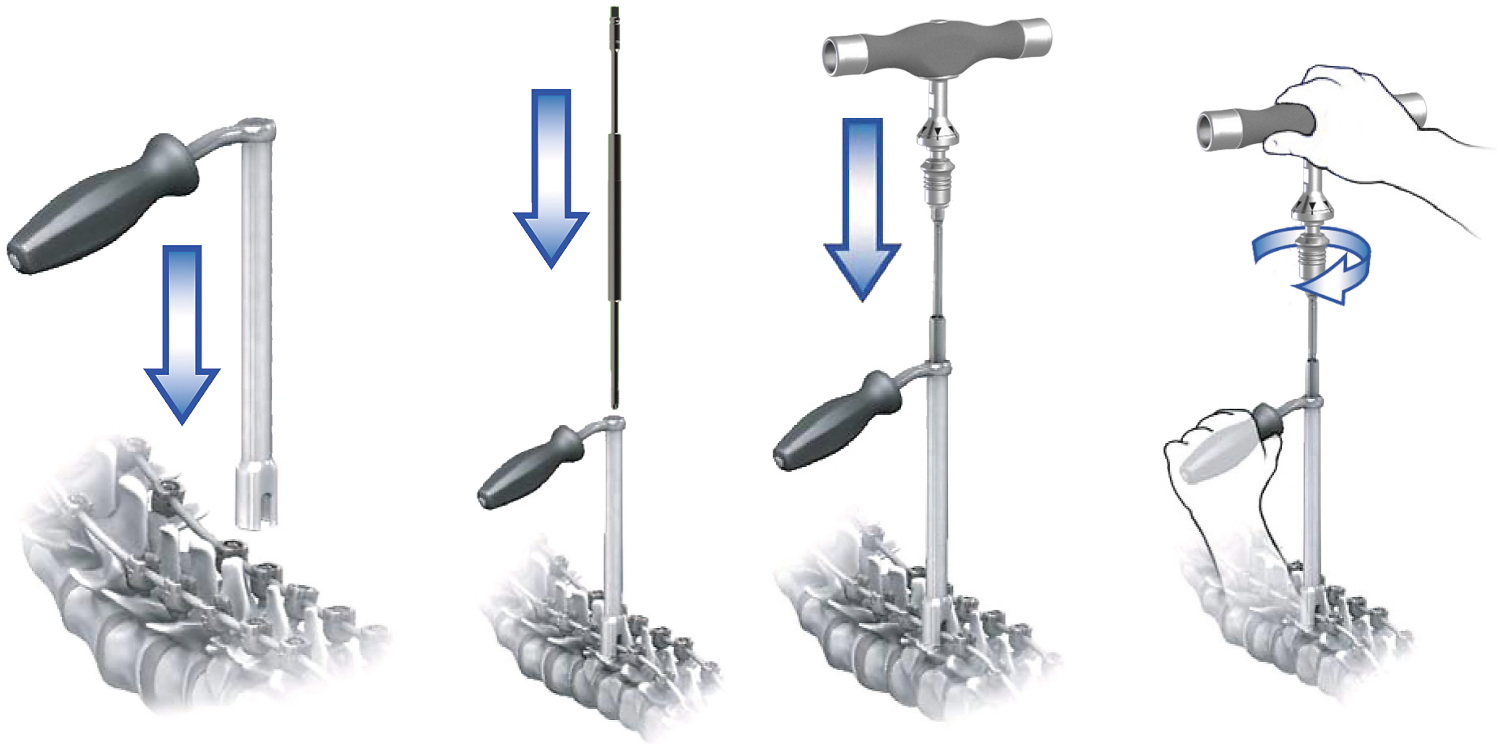

Final Tightening

To final tighten all open pedicle screw assemblies, seat the Counter Torque Wrench and the Final Set Screw Driver Shaft (01-1300-9100) onto the open screw, saddle, and set screw.

Place the gray Set Screw Torque Limiter T-Handle (13 N-m) on the Driver Shaft, and turn the handle clockwise while firmly holding the Counter Torque Wrench.

Turn the T-handle until two audible clicks are heard, indicating that proper torque has been met.

NOTE: The Gray T-handle (13 N-m) or the 14 N-m (Dark Gray Collar) Single Use Torque Limiter is only to be used with the large set screw driver for large set screws using the 5.5mm/6.0mm system.

WARNING: Ensure set screw is properly tightened with provided Gray Set Screw Torque Limiter T-Handle, or with the 14 N-m (Dark Gray Collar) Single Use Torque Limiter attached to Fixed Ratcheting T-Handle. Failure to fully seat the torque driver in the set screw can lead to damage or disassociation of set screw postoperatively

When final torque is complete a squeaking sound is often heard. This is by design and part of the science of the RESPONSE Spine System thread technology. This squeaking is caused by an effect called “galling” or cold welding. By utilizing this science, the large set screw and tulip head interface self-locks upon final torque.

Ensure set screw is properly seated within the pedicle screw following final torque (Figure 3). When utilizing a 6.0mm rod, the set screw will be flush with the pedicle screw head. When utilizing a 5.5mm rod, the set screw will be slightly recessed within the pedicle screw head.



FIGURE 3: Proper seating of set screw within pedicle screw showing using the 5.5mm/6.0mm system.

NOTE: when using the 5.5mm ONLY system, the set screw is flush upon final torque.

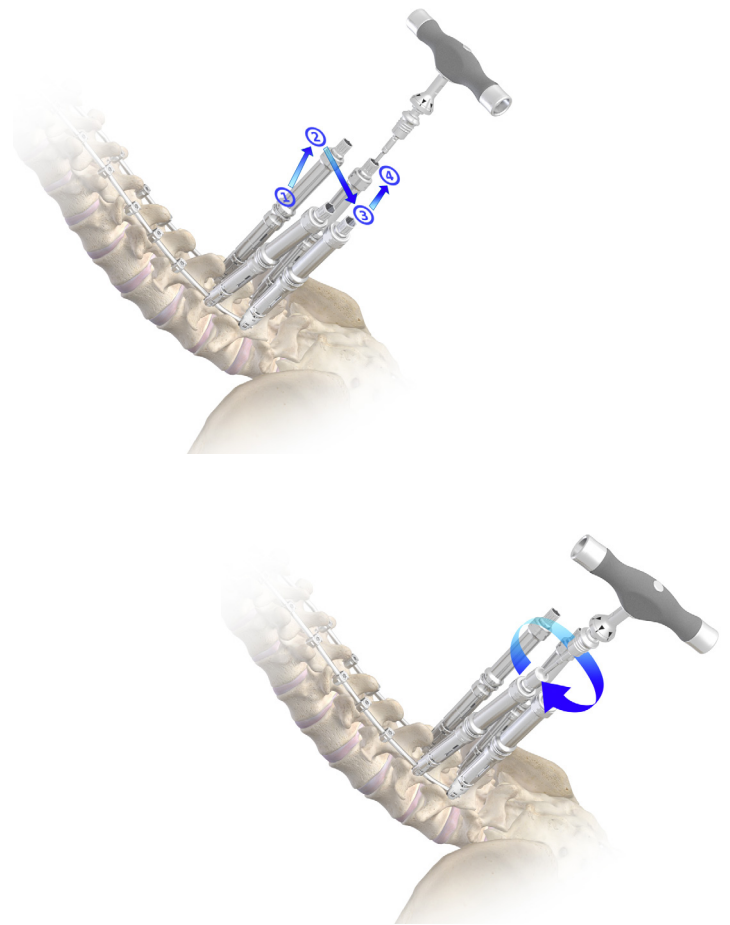
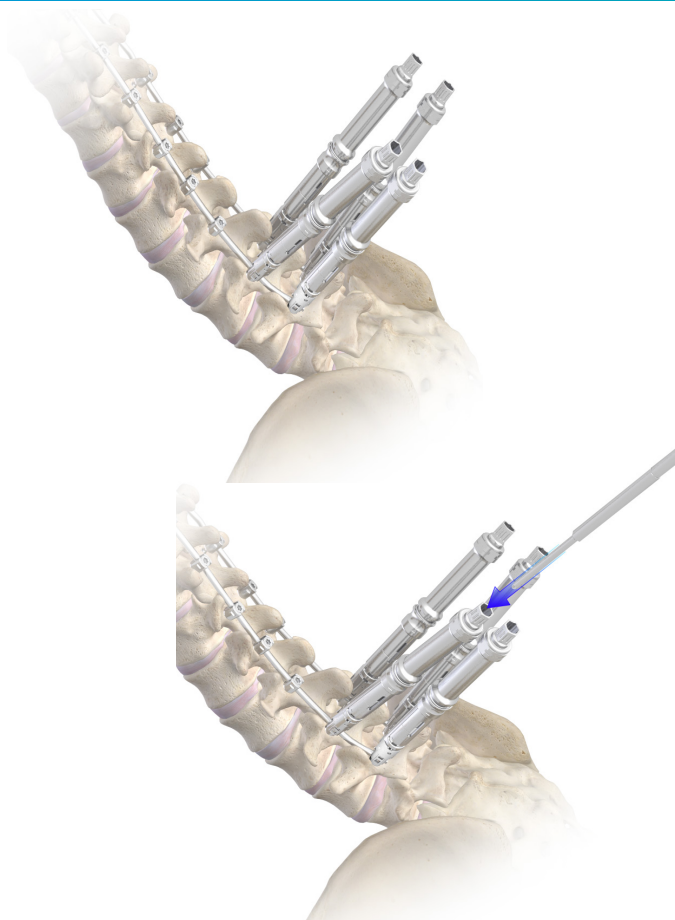

Final Tightening at the Bottom of the Construct

In the context of the OrthoPediatics RESPONSE system, use the towers in the lower two levels, as shown below. This will ensure that the rod is fully seated.

- 1 Tighten the towers sequentially to ensure that the rod is properly seated in the tulip head.
- 2 Tighten the set screws utilizing the gray T-handle (13 N-m) in the sequence shown to the left at the last two levels sequentially from cephalad to caudal.
- 3 Turn the gray T-handle (13 N-m) until two audible clicks are heard, indicating that proper torque has been met.

NOTE: the illustration shown is using the 5.5mm/6.0mm system.

**See Page 36 for Final Tightening - Alternate Instruments*

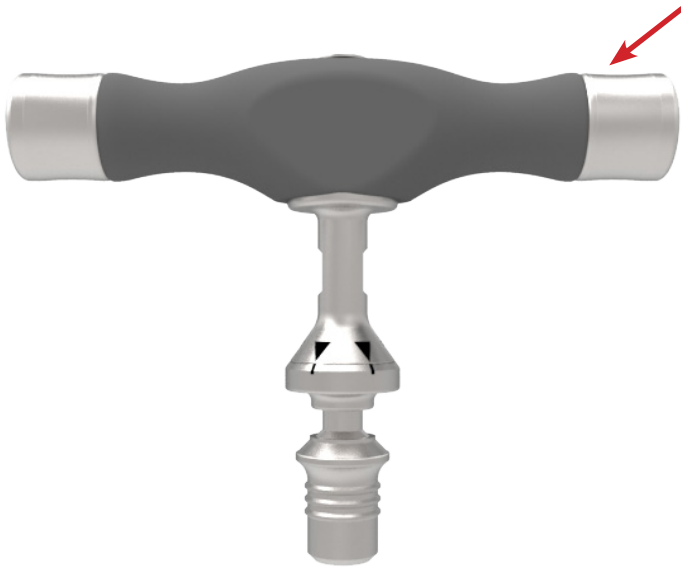
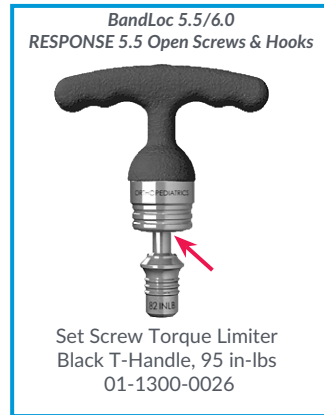
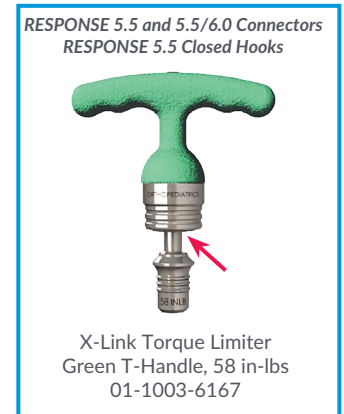

Figure 1

Final Tightening Summary

When completing final tightening, it is important to remember these key points.

- 1 Verify the expiration date on the torque limiter. The area where the expiration date can be found is designated by the **red arrows** shown above.



- 2 Utilize the correct Torque Limiter.

FINAL TIGHTENING - ALTERNATE INSTRUMENTS

Fixed Ratcheting T-Handle
01-1600-0027



Manual Single Use Set Screw Torque Limiter
Dark Gray Sleeve; 14 N-m
803-003

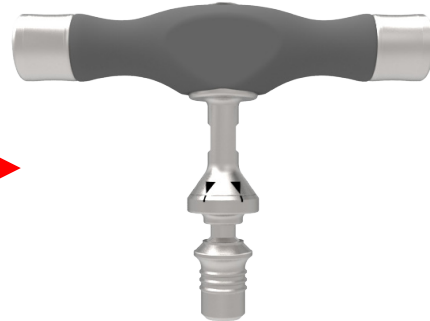

Set Screw Torque Limiter
Gray T-Handle, 13 N-m*
01-1300-4000

NOTE: Fixed Ratcheting T-Handle attached to 14 N-m Single Use Torque Limiter (Dark Gray Sleeve) can be used in place of the Gray T-Handle 13 N-m Set Screw Torque Limiter at any step of this surgical technique.

Two clicks are required with either instrument to lock the construct.

Both the 14 N-m Single Use Torque Limiter and the 13 N-m Gray T-Handle Torque Limiter have been tested with torque limiting ranges that effectively lock the implant construct.

Fixed Ratcheting T-Handle
01-1600-0027



Manual Single Use Set Screw Torque Limiter
Blue Sleeve; 7 N-m
803-001



X-Link Torque Limiter
Green T-Handle, 58 in-lbs*
01-1003-6167

NOTE: Fixed Ratcheting T-Handle attached to 7 N-m Single Use Torque Limiter (Blue Sleeve) can be used in place of the Green T-Handle 58in-lb X-Link Torque Limiter at any step of this surgical technique.

Both the 7 N-m Single Use Torque Limiter (Blue Sleeve) and the 58in-lb Green X-Link T-Handle Torque Limiter have been tested with torque limiting ranges that effectively lock the implant construct.



Reduction Screws

If reduction screws or reduction hooks are being utilized within the construct, use the Tab Breaker at this time to remove the extended tab on each pedicle screw and reduction hook.

CAUTION: Use care when using the Tab Breaker to avoid injury to both patient and physician.

HOOK SURGICAL TECHNIQUE

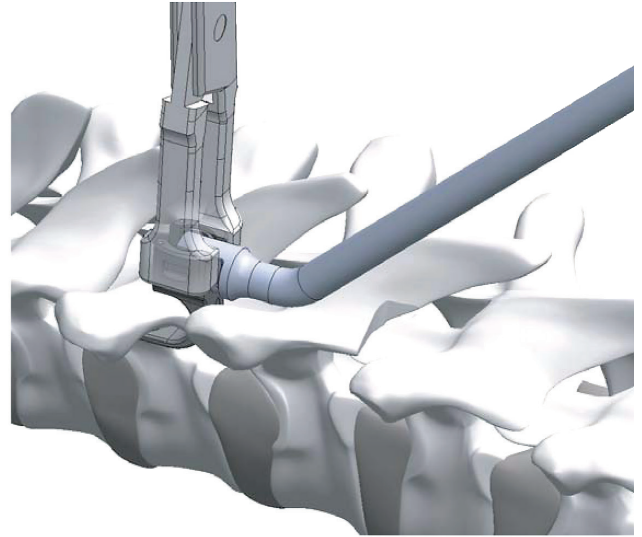
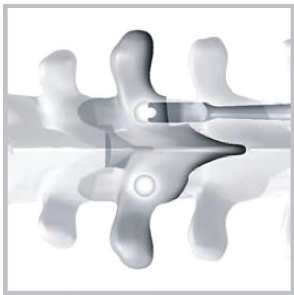
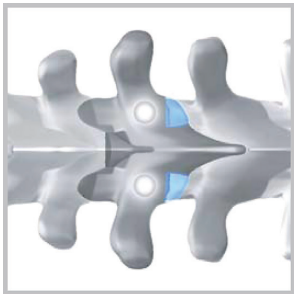

Hook Site Preparation – Pedicle Hook

The facet capsule is divided; a portion of the inferior facet process may be removed to facilitate insertion of the hook.

Clearly identify the pedicle with the help of the Pedicle Elevator and insert the hook. The Pedicle Hook may be used from T1 to T10. Place the hook blade cephalad (up-going) and in the infralaminar position.

The facet capsule is divided; a portion of the inferior facet process may be removed to facilitate insertion of the hook. If necessary, use a Hook Pusher on the Pedicle Hook. The Pedicle Hook must be placed into the joint cavity and must not split the inferior articular process.

NOTE: Use care when inserting hook with the hook holder, avoiding excessive force so as to not break the pedicle or disengage the holder.

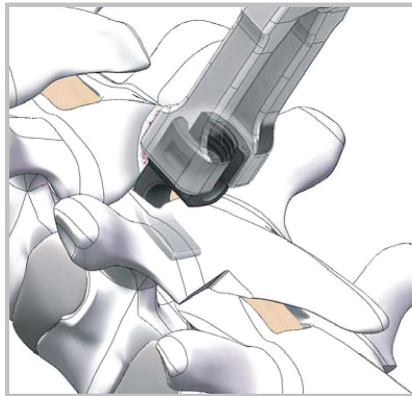
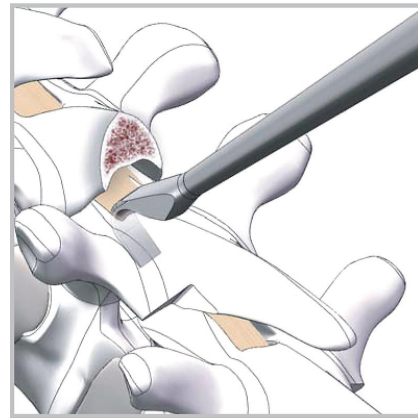

Hook Placement

Hook Placement at the Transverse Process

A Wide Blade Hook is typically used in a pedicle transverse claw construct as a caudal (down-going) hook. Laminar Hook Trials may be used to separate the ligamentous attachment between the under-surface of the transverse process and the posterior arch of the rib medial to the rib-transverse joint. Use a Hook Holder to insert these hooks.

Thoracic Hooks

A partial or total division of the spinous process directly above the vertebra to be instrumented (thoracic vertebra) may be performed. A division and/or partial removal of the ligamentum flavum and a small laminotomy are carried out on the superior lamina. The amount of bone removed from the lamina may vary depending on the size of the hook blade and throat angle chosen. The upper edge of the lamina below or the lower edge of the lamina above may be resected to ease the placement of this hook. The Laminar Hook Trial may be used to check the space between lamina and peridural structures. Two widths of Laminar Hook Trials are available depending on the size of the lamina: Narrow or Wide Blade. Use a Hook Holder to insert the hook when placed on the superior lamina.



In-Situ Benders



French Bender

Rod Contouring

After placing the appropriate hooks on the side of the deformity to be corrected, the rod template may be used to measure the length and the curve. The rod on the corrective side will need to be cut 2-3cm longer than the actual length to leave adequate length for correction. The rod can then be bent into the correct orientation using either the in-situ benders or french bender. Consult pages 23 and 30 regarding neuromonitoring.

Once Inserted, some hooks may not be stable prior to rod insertion. It is recommended to remove these hooks and keep them on the Staging Tray.

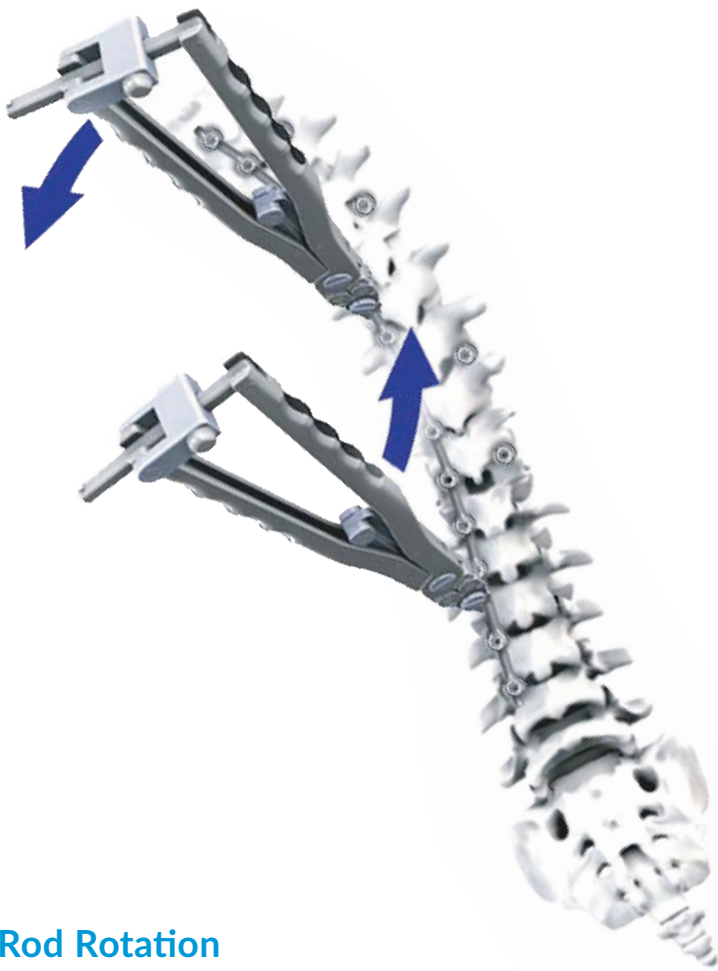

Rod Rotation

See pages 25-29 to reference rod reduction and contouring. At this point of the surgery part of the correction has been achieved, mainly due to translation maneuvers used when inserting the rod. Further correction can be accomplished with rod rotation and/or in-situ bending, depending on the type and stiffness of the curve, and completed with compression/distraction maneuvers.

Once the rod is secured, introduce the set screws with the appropriate set screw starters (Small Set Screw Starter for closed hooks, T-30 Large Set Screw Driver for open hooks.)

Once the contoured rod and all of the set screws have been placed, the rod is ready to be rotated into its final position. The rotation must be done slowly in order to prevent rapid neurologic changes and/or injury to the spinal cord. The rotation is done using two Rod Grippers. It is important to monitor the interval hooks, which tend to back out during rod rotation.

Use the Rod Pusher or place the Rod Gripper on the rod just below the hook to buttress it.



In-Situ Bending

Once the rotation of the rod is complete and the position of the hooks is verified, provisionally tighten the set screws in the interval hooks to prevent rod derotation. Provisionally tighten the set screws using the T-30 Large Set Screw Driver for Large Set Screws and the T-20 Small Set Screw Driver for Small Set Screws.

Check the hooks following all rotation maneuvers and make necessary adjustments to ensure that proper placement is maintained.

At this point, the rod should be fully seated into the saddle of all of the implants.

The in-situ benders may be used for correction and final adjustment of the rod in the sagittal and/or coronal plane. The rod is bent in small incremental steps using the two bender tips positioned near each other on the rod.

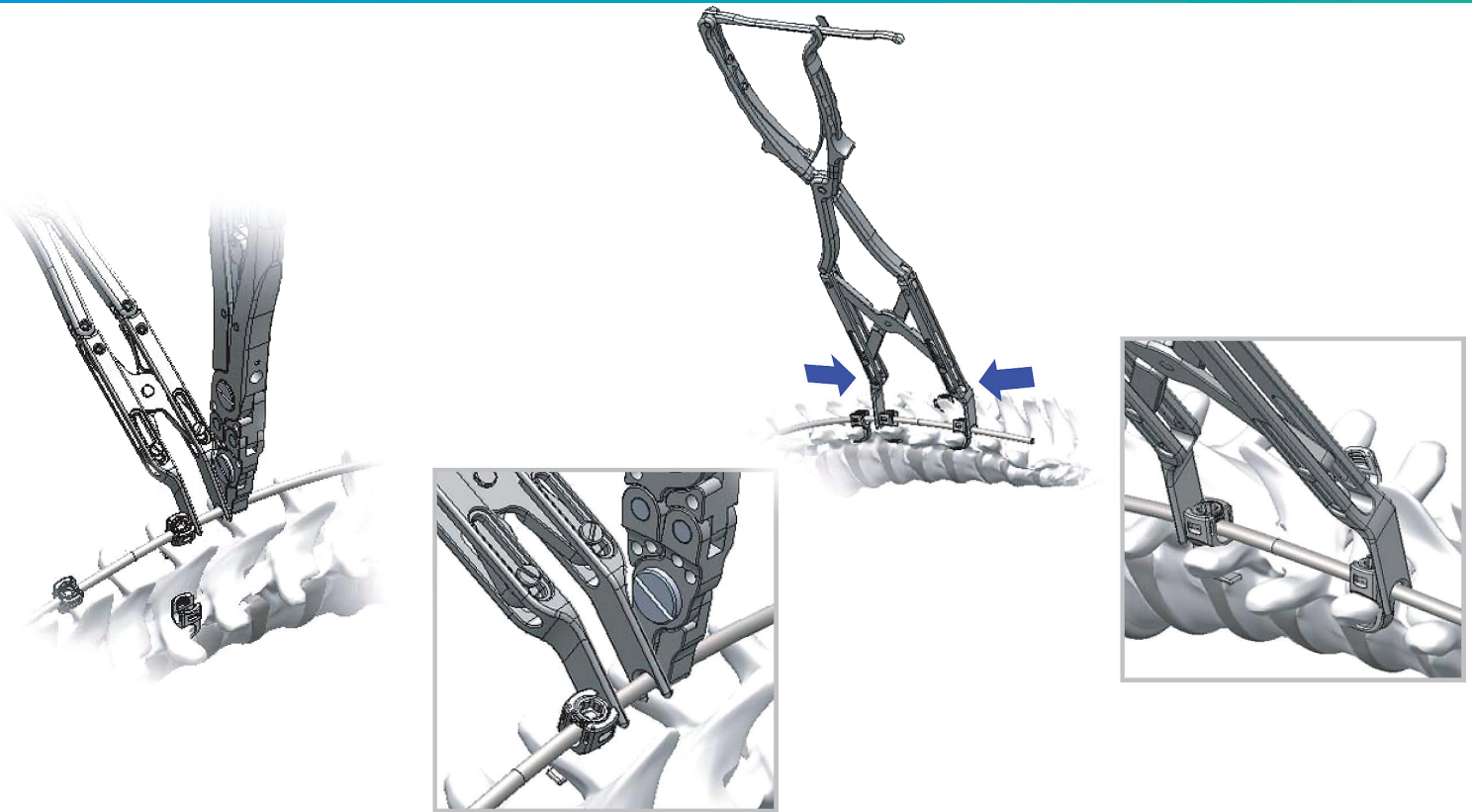

Compression/Distraction

Once the rod is secured in the implants, perform distraction and/or compression to place the hooks in their final position. The Compressor, Distractor, and Rod Gripper are used to carry out these maneuvers. It is recommended to use the Rod Gripper as a stop for distraction maneuvers rather than the implant.

Care should be taken to ensure that the foot of either instrument is placed against the implant body and not against the set screw. It is preferred that compression be released just prior to the set screw

being final tightened. This technique will help ensure that the implant head and rod are normalized to one another and thus allow for the rod to be fully seated in the implant head during the final tightening step. After these maneuvers are complete, the set screw is tightened with the black Torque Limiter T-Handle (95 in-lbs) for open hooks, or with the green Torque Limiter T-Handle (58 in-lbs) for closed hooks.



Stabilization Rod Placement

With the completion of the deformity correction and the seating of the correction rod, the opposite side of the construct is prepared. Measure the length for the stabilizing rod, then cut.

Using the French Bender, contour the rod according to the curvature of the spine and the residual position of alignment from the correction rod.

Place the contoured rod into the hooks with rod gripper or by hand and provisionally secure the rod with set screws. Once the rod is secured to the implants, perform distraction and/or compression to place the hooks in their final position. Refer to Page 41 to ensure the appropriate steps are followed. Do not final tighten set screw under compression.

NOTE: The spine may be decorticated to carry out the bone fusion and morselized cancellous bone placed along the decorticated spine, extending out over the transverse processes.

The RESPONSE Systems utilizes Set Screws. The following Torque Limiter T-Handles must be used to final tighten the Set Screws based on the implant selection; the gray Set Screw Torque Limiter T-Handle (13N-m [115in-lbs]) is used with 5.5/6.0 open hooks, the black Set Screw Torque Limiter T-Handle (95in-lbs) is used with 5.5 open hooks, the green Set Screw Torque Limiter T-Handle (58in-lbs) is used with closed hooks.

WARNING: Ensure set screw is properly tightened with the correct Set Screw Torque Limiter T-Handle. Use of incorrect Set Screw Torque Limiter T-Handle can lead to disassociation of the set screw postoperatively.

CROSS CONNECTOR TECHNIQUE

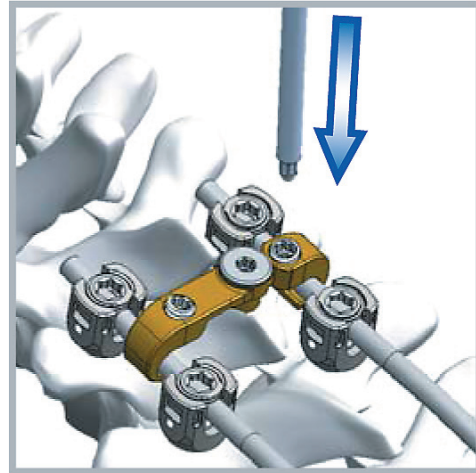

X-Link Placement

After final tightening of the set screws, it is critical to place cross connectors. These links provide rotational stability to the construct. A framed construct resists rotational forces. Ideally, the cross connectors should be placed close to the proximal or distal end of the construct.

Cross Connectors:

Capture both rods and confirm placement. Place Small Set Screws using the Small Set Screw Starter. Provisionally tighten using the Small Set Screw Driver to secure the connector to the rods.

Provisionally tighten the midline nut to gain control of the linkage device during placement.

Capture the far rod (in relation to the surgeon) of the two rods to be stabilized. Use the Small Set Screw Driver to provisionally tighten to anchor the device to this rod.

Loosen the midline nut to allow the linkage to capture the other rod, then anchor the linkage by seating the set screw to the rod. Re-tighten the midline nut to secure the link.

For final tightening, Seat the Counter Torque Tube and the Small Set Screw Driver onto the connector, rod, and set screw.

Then turn the green T-handle (58 in-lbs) of the Driver Shaft while firmly holding the Counter Torque Wrench.

Turn the T-handle until an audible click is heard, indicating that proper torque has been met.

Repeat the tightening procedure on the remaining Small Set Screw.

Final tighten the midline screw. Seat the Small Set Screw Driver over the midline screw, then turn the green T-handle (58 in-lbs) until an audible click is heard, indicating that proper torque has been met.

**See Page 36 for Final Tightening - Alternate Instruments*

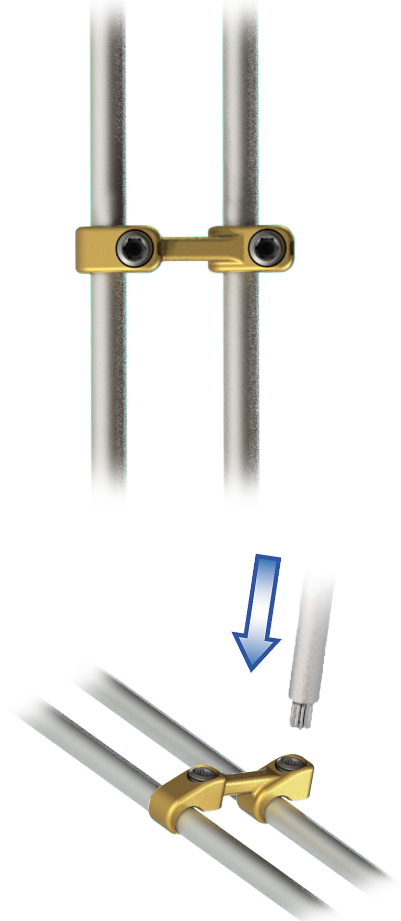
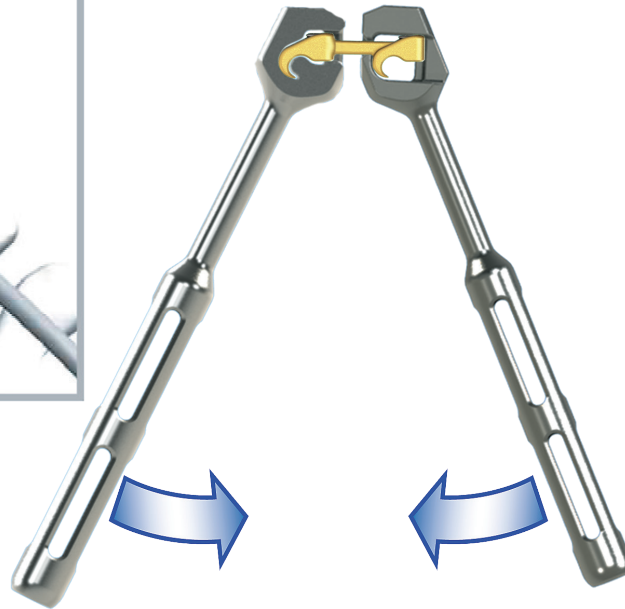
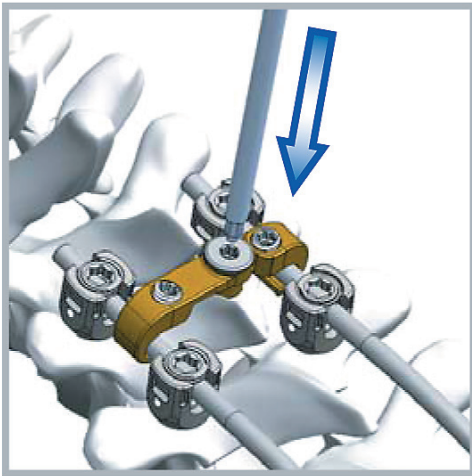

NOTE: For insertion of Inline Dual Diameter Connectors, Domino Inline Dual Diameter Connectors, Wedding Band Inline Dual Diameter Connectors, and the Closed Lateral Connectors, Place Small Set Screws with the Small Set Screw Starter, provisionally tighten using the Small Set Screw Driver.

CAUTION: Final tighten with the Small Set Screw Driver mounted on the green T-handle (58 in-lbs). Turn the T-handle until an audible click is heard, indicating that proper torque has been met.

Fixed Cross Connector

Capture both rods and confirm placement. Provisionally tighten using the X-Link Screw Driver Shaft to secure the connector to the rods.

For final tightening, Seat the Counter Torque Tube and the X-Link Screw Driver Shaft onto the connector, rod, and set screw.

Then turn the green T-handle (58 in-lbs) of the Driver Shaft while firmly holding the Counter Torque Wrench. Repeat for the remaining set screw.

For some applications, the arm of the Fixed Cross Connector may need to be bent. Use the X-Link Benders to modify the angle to best fit the anatomy and rod arrangement.

CAUTION: Do not rebend cross connectors.

**See Page 36 for Final Tightening - Alternate Instruments*

REVISION OR REMOVAL TECHNIQUE

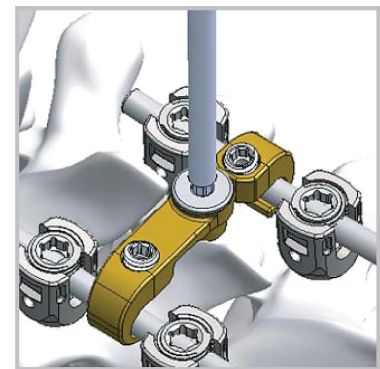
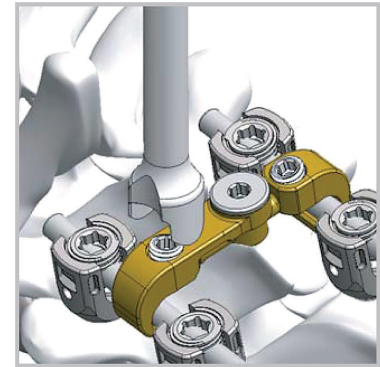
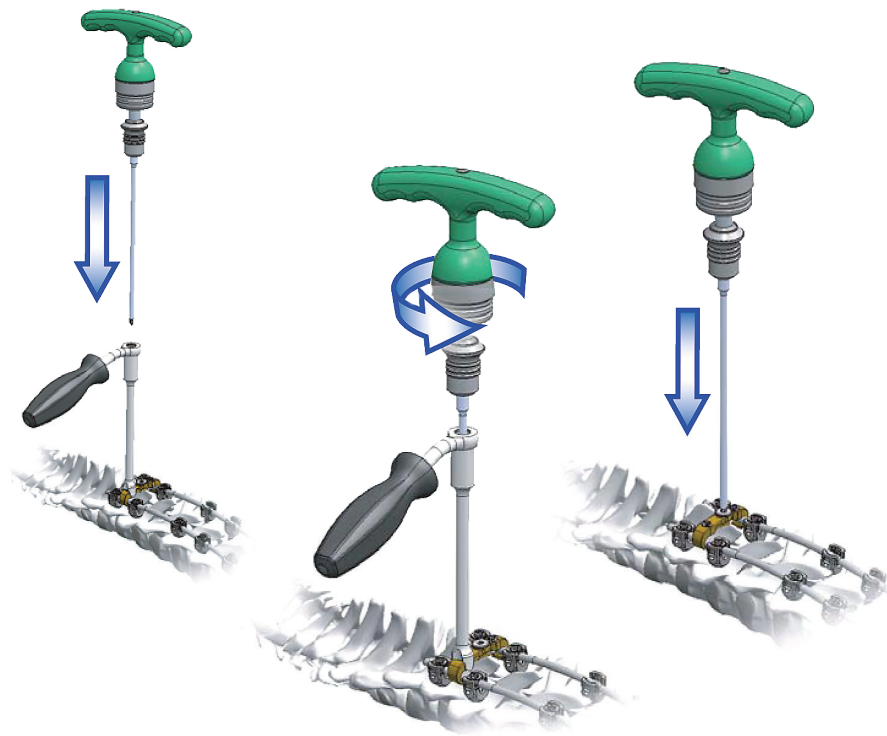

Cross-Connector Removal

Place the X-Link Counter Torque Tube and the Small Set Screw Driver over the connector, rod, and set screw of the rod closest to the surgeon. Use the Small Set Screw Driver and T-handle to remove the set screw while firmly holding the Counter Torque Tube.

Loosen the midline nut with the Small Set Screw Driver to release the linkage from the rod (disregard this step if releasing a fixed cross connector).

**See Page 36 for Final Tightening - Alternate Instruments*

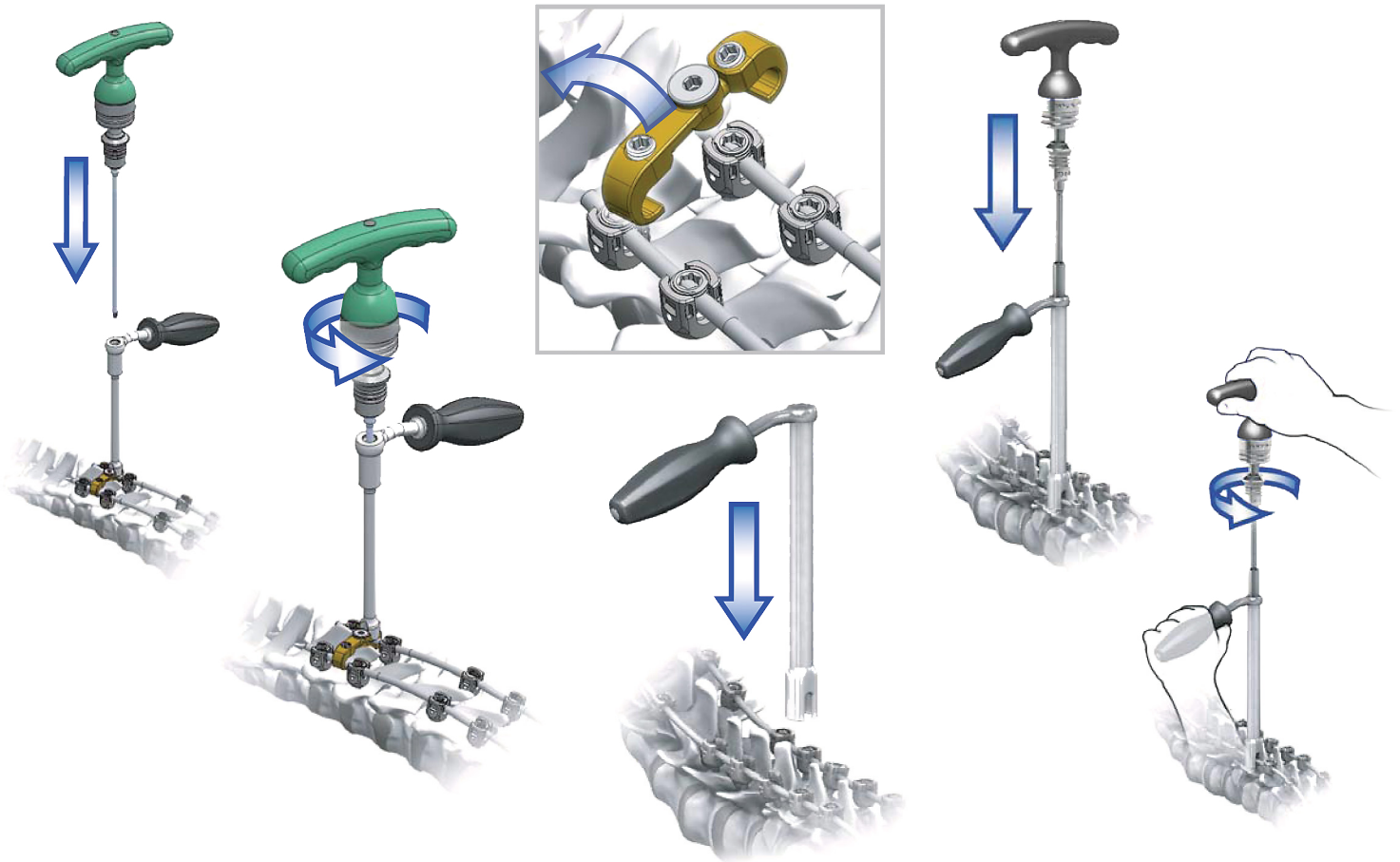

Cross-Connector Removal

Use the X-Link Counter Torque Tube and the Small Set Screw Driver to remove the set screw from the remaining cross connector, and remove the assembly.

Set Screw Removal

Place the Counter-Torque Wrench over the rod and Pedicle Screw to provide the leverage needed to loosen the Set Screw. Hold the wrench firmly and remove the Set Screw by turning it counter clockwise with the Large Set Screw Driver.

**See Page 36 for Final Tightening - Alternate Instruments*

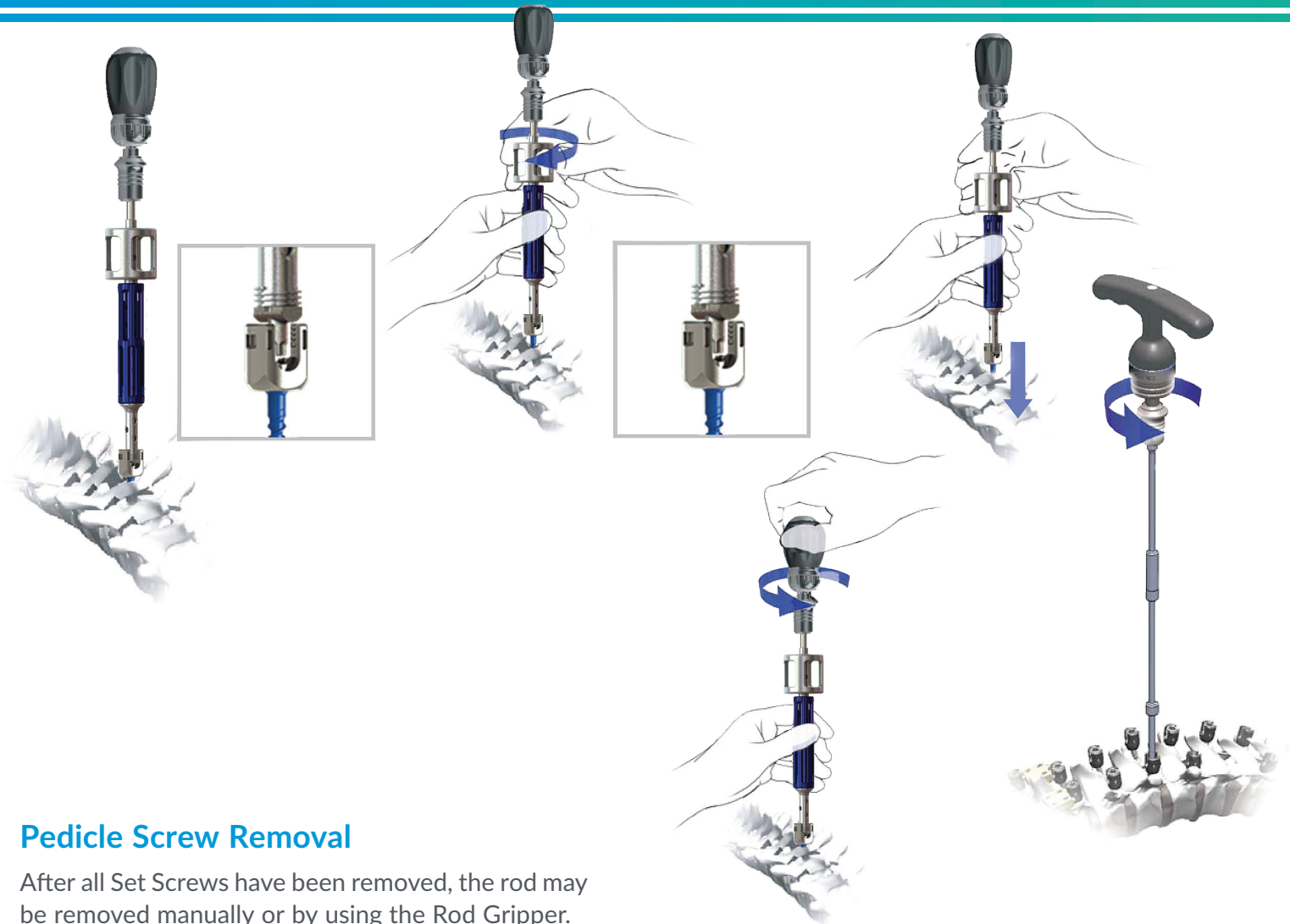

Pedicle Screw Removal

After all Set Screws have been removed, the rod may be removed manually or by using the Rod Gripper.

- 1 Place the hexalobe tip of the driver into the screw until it is seated as shown.
- 2 Turn the threading knob to thread the driver to the screw.
- 3 Engage the rotation sleeve by pushing it down into the head of the screw.

Alternate Method

Use the T-20 Pedicle Screw Positioner to remove the Pedicle Screw.

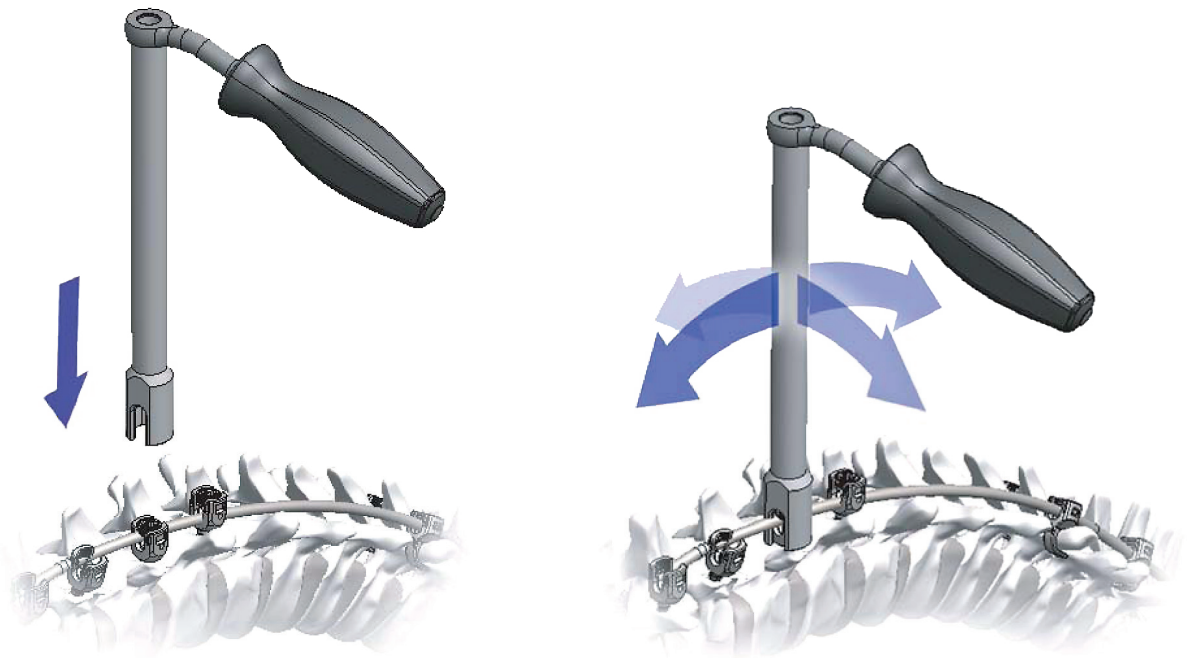

Screw Extraction

If it is necessary to unlock the head of the pedicle screw, place the Counter-Torque Wrench over the screw. Tilt the wrench about 25 degrees. An audible pop may be heard to indicate that the head has been unlocked.

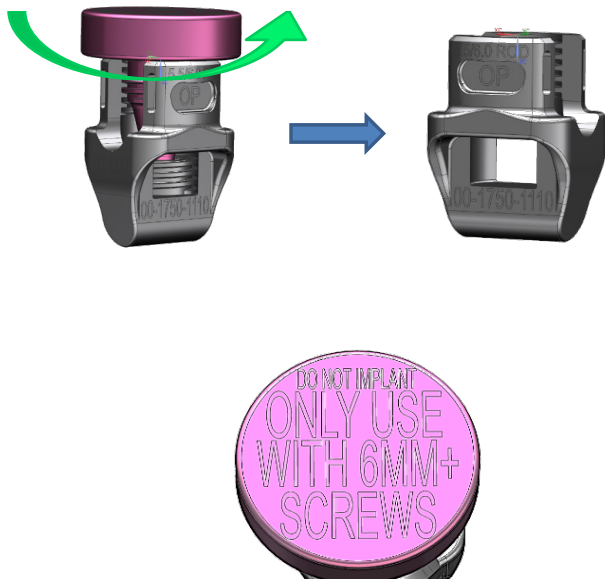

Auxillary Implants for Neuromuscular Indications

NOTES & WARNINGS:

- Screw Body Extensions only to be used with 6mm and larger pedicle screws
- Do not stack body extensions
- Do not use on most cephalad or caudal pedicle screw
- Remove and discard Warning Cap prior to use

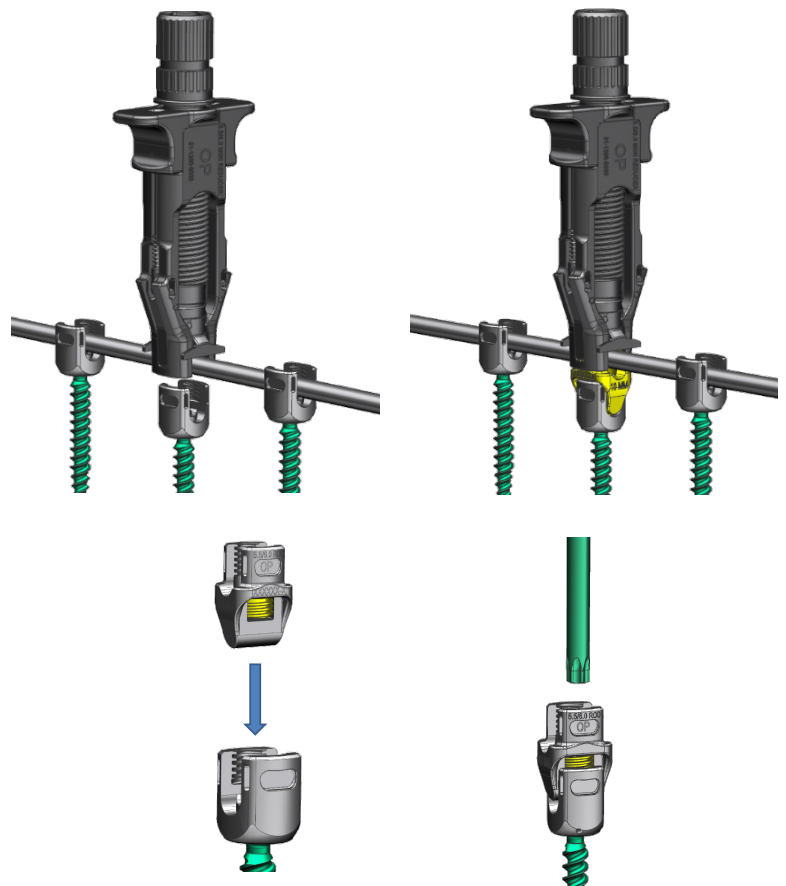

Reduction Technique

- In locations where extreme spinal curvature results in a large differences in height between pedicle screw and rod, and rod reduction is limited. Screw body extension can be used to span height.
- Place screw body extension over pedicle screw, slotting lower portion of body extensions into pedicle screw Rod Slot.
- Using Final Torque Drive (01-1300-9100), provisionally tighten internal set screw (shown in yellow) into head of pedicle screw.

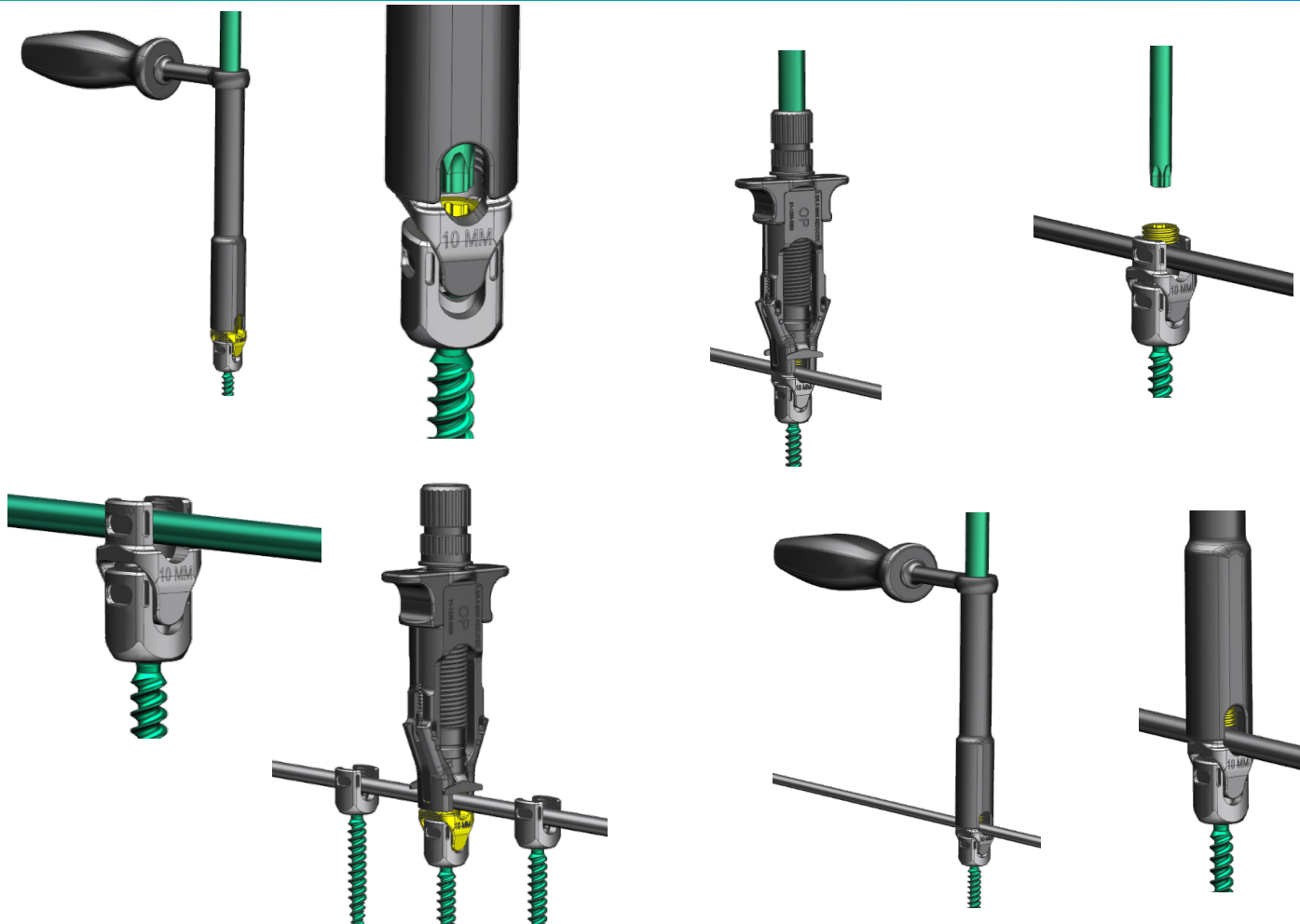

Using Countertorque (01-1300-0028) and Final Torque Drive (01-1300-9100), final tighten body internal set screw (shown in yellow) per Final Tightening section on page 33.

Place rod into body extension rod slot and attach Rod reducers to body extension. Reduce Rod.

Using Final Torque Drive (01-1300-9100), provisionally tighten large set screw as shown on page 30.

Using Countertorque (01-1300-0028) and Final Torque Drive (01-1300-9100), final tighten large set screw (shown in yellow) per the Final Tightening section.

IMPORTANT MEDICAL INFORMATION

Contra-Indications

Metallic bone fixation devices should not be used in patients with:

- active systemic infection or infection localized to the site of implant
- a demonstrated sensitivity to metals
- an inability to follow a post-operative regimen

Relative contraindications include any condition that precludes the possibility of fusion (e.g., cancer, kidney dialysis) or that produces loads on the device that could lead to failure (i.e., obesity).

Warnings

- Federal (USA) law restricts this device to sale by or on the order of a physician.
- The safety and effectiveness of this device has not been established for use as part of a growing rod construct. This device is only intended to be used when definitive fusion is being performed at all instrumented levels.
- The safety and effectiveness of pedicle screw spinal systems have been established only for spinal conditions with significant mechanical instability or deformity requiring fusion with instrumentation. These conditions are significant mechanical instability or deformity of the thoracic, lumbar, and sacral spine secondary to severe spondylolisthesis (grades 3 and 4) of the L5-S1 vertebra, degenerative spondylolisthesis with objective evidence of neurological impairment, fracture, dislocation, scoliosis, kyphosis, spinal tumor, and failed previous fusion (pseudoarthrosis). The safety and effectiveness of these devices for any other conditions are unknown.
- Use extreme care in handling and storage of implants and instruments. Cutting, bending or scratching the surface of metallic components can significantly reduce fatigue strength or corrosion resistance of the implant or instrument.
- Mixing of implants from different suppliers is not recommended for reasons of metallurgy, mechanics and design. OrthoPediatrics declines all responsibility in the case of implants from different sources being mixed.

- Repeat use of a surgical implant is strictly forbidden. Each implant used once must be disposed properly. Even though the device may appear intact, the device may have small faults or internal stresses that if the implant was re-used may lead to fatigue failure.
- Care should be taken not to cut through surgical gloves when handling any sharp-edged surgical instrument and to take into account the risk of infection if a cut appears.

MRI Safety Information

In non-clinical testing the OrthoPediatrics implants were determined to be MR-Conditional. A patient with this device can be safely scanned immediately after device placement under the following conditions:

Static Magnetic Field

- Static magnetic field of 1.5 Tesla and 3.0 Tesla
- Maximum spatial gradient magnetic field of 2000 Gauss/cm or less
- Maximum whole-body average specific absorption rate (SAR) of 1.0 W/kg or less for 15 minutes of scanning per pulse sequence

MRI-Related Heating

- Based on measurements and calculations of RF heating according to ASTM F2182-11a, the OrthoPediatrics RESPONSE Spine system is expected to produce a maximum temperature rise of 6.75°C for a whole-body SAR of 1.0 W/kg for a 15-minute scan.

Artifact Information

- MR image quality may be compromised if the area of interest is in the same area or relatively close to the position to OrthoPediatrics implants. The maximum artifact beyond the implant was 55 mm for the spin echo sequence and 60 mm for the gradient echo sequence in a 3.0 Tesla MR system (GE Signa HDxt MR System). Therefore, optimization of MR imaging parameters to compensate for the presence of this device may be necessary. The presence of other implants or the health state of the patient may require a modification of the MR conditions.

Precautions

- The implantation of pedicle screw spinal systems should be performed only by experienced spinal surgeons with specific training in the use of this system because this is a technically demanding procedure presenting a risk of serious injury.
- Before clinical use, the surgeon should thoroughly understand all aspects of the surgical procedure and the limitations of the instrumentation. Pre-operative procedures, knowledge of applicable surgical techniques, proper patient selection, correction selection and placement of implants are all equally important for the successful use of these products.
- Postoperative care is extremely important. The patient must be instructed in the limitations of the metallic implant regarding weight bearing and body stresses on the device prior to firm bone healing. Until the bone is fully healed, the patient should not return to activities that include heavy lifting, twisting, bending, stooping, running, or strenuous walking. The patient should be warned that noncompliance with postoperative instructions could lead to failure of the implant and the possible need thereafter for additional surgery to remove the device.
- Based on the fatigue testing results, the physician/surgeon should consider the levels of implantation, patient weight, patient activity level, other patient conditions, etc. which may impact on the performance of the system.
- These devices are not intended or expected to be the only mechanism for support of the spine. No implant can be expected to withstand indefinitely the unsupported stress of full weight bearing. Without solid biological support provided by spinal fusion, the devices cannot be expected to support the spine indefinitely. Resultant failure modes may include bone-metal interface failure, implant fracture or bone failure. Following surgery, bracing may be used at the surgeon's discretion.
- When using posterior spinal instrumentation in a pediatric population, it is preferable that patients are 12 years of age or older but need not have reached skeletal maturity. In special circumstances, implants may be used at younger ages. Since pediatric patients may have additional growth potential following implant surgery, the likelihood of a subsequent removal and/or revision surgery is greater than in adults.
- Implant Retrieval. The final decision to recover the implant falls to the surgeon. If the patient is suitable, OrthoPediatrics recommends the retrieval of implants as otherwise they may replace the function of the bone and lead to bone reduction and weakening. This is especially important for young and active patients. Routine removal of internal fixation devices after healing may also reduce the occurrence of symptomatic complications of implant breakage, implant loosening or implant related pain.
- It is important that the surgeon exercise extreme caution when working in close proximity to vital organs, nerves, or vessels, and that the forces applied while correcting the position of the instrumentation is not excessive, such that it might cause injury to the patient.
- There are particular risks involved in the use of instruments used for bending and cutting rods. The use of these types of instruments can cause injury to the patient by virtue of the extremely high forces involved. Do not cut rods in situ. The physical characteristics required for many instruments does not permit them to be manufactured from implantable materials, and if any broken fragments of the instruments remain in the body of a patient, they could cause allergic or infectious consequences.
- Over-bending, notching, striking and scratching of the implants with any instrument should be avoided to reduce the risk of breakage. Under no circumstances should rods be sharply or reverse bent, because doing so could significantly reduce the fatigue life of the rod and increase the risk of breakage. When the configuration of the bone cannot be fitted with an available device and contouring of the device is absolutely necessary, contouring should be performed only with the proper bending equipment, and should be performed gradually and with great care to avoid notching or scratching the device.
- Surgeons should be careful to insure proper soft tissue coverage over implants.



- CAUTION:** Federal law restricts this device to sale by or the order of a Physician.
- CAUTION:** Implants are supplied Non-Sterile. Clean and sterilize before use according to instructions.
- CAUTION:** Implants components are single-use. Do not reuse.
- CAUTION:** Only those instruments and implants contained within this system are recommended for use with this technique. Other instruments or implants used in combination or in place of those contained within this system is not recommended, unless otherwise stated.
- NOTE:** This technique has been provided by one of our medical advisors only as guidance and it is not intended to limit the methods used by trained and experienced surgeons.

This document is intended exclusively for experts in the field, i.e. physicians in particular, and expressly not for the information of laypersons.

The information on the products and/or procedures contained in this document is of general nature and does not represent medical advice or recommendations. Since this information does not constitute any diagnostic or therapeutic statement with regard to any individual medical case, individual examination and advising of the respective patient are absolutely necessary and are not replaced by this document in whole or in part.

The information contained in this document was gathered and compiled by medical experts and qualified OrthoPediatics employees to the best of their knowledge. The greatest care was taken to ensure the accuracy and ease of the understanding of the information used and presented. OrthoPediatics does not practice medicine and does not recommend any particular orthopedic implant or surgical technique for use on a specific patient. The surgeon is responsible for determining the appropriate device(s) and technique(s) for each individual patient.

OrthoPediatics does not assume any liability, however, for the timeliness, accuracy, completeness or quality of the information and excludes any liability for tangible or intangible losses that may be caused by the use of this information.

OrthoPediatics, ArmorLink, BandLoc Duo, PediFlex, PediFoot, PediFrag, PediGraft, PediLoc, PediNail, PediPlates, PLEO, QuickPack, RESPONSE, Scwire, ShieldLoc, TorqLoc, PediPedal and the OP and Pedi logos are trademarks of OrthoPediatics Corp. ApiFix and Orthex are trademarks of wholly-owned subsidiaries of OrthoPediatics Corp.

OrthoPediatics is a registered trademark in Brazil, S.Korea, and the U.S.A. PediLoc and PediPlates are registered trademarks in Chile and the U.S.A. The OP logo is a registered trademark in Colombia, European Union, Japan, and the U.S.A. The Pedi logo is a registered trademark in Argentina, Australia, Brazil, Chile, Colombia, European Union, Israel, Mexico, New Zealand, S.Korea, Taiwan, Turkey, and the U.S.A. ApiFix is a registered trademark in the U.S.A. ArmorLink is a registered trademark in the U.S.A. Scwire is a registered trademark in the U.S.A. ShieldLoc is a registered trademark in the U.S.A. TorqLoc is a registered trademark in the U.S.A. BandLoc Duo is a registered trademark in the U.S.A. Orthex is a registered trademark in the U.S.A. QuickPack is a registered trademark in the U.S.A.



2850 Frontier Drive | Warsaw, IN 46582
ph: 574.268.6379 or 877.268.6339 | fax: 574.268.6302
www.OrthoPediatics.com

CE 2797

CE Mark is valid only if also printed on the product label or device itself

© 2022 ORTHOPEDIATRICS - ST-1300-01-01 REV I (March 2022).